



SERVICE MANUAL (KC)

ROUGH TERRAIN SCISSORS

MODEL **SJ9250 RT**

157957AD February 2014

SKYJACK[™]

This manual is based on Serial Number(s):

SJRT 9250 50,000,746 to 50,001,023

Please refer to the website (www.skyjack.com) for older Serial Numbers.

Skyjack Service Center

3451 Swenson Ave. St. Charles,
Illinois, 60174 USA
Phone: 630-262-0005
Toll Free: 1-800-275-9522
Fax: 630-262-0006
Email: service@skyjack.com

Parts (North America)

Toll Free: 1-800-965-4626
Toll Free Fax: 1-888-782-4825
E-mail: parts@skyjack.com

Skyjack Australia Pty Ltd.

4 Coates Place
Wetherill Park
New South Wales 2164
Australia
Tel: +61 (0) 28786 3200
Fax: +61(0) 28786 3222

Parts & Service (Europe)

Unit 1 Maes Y Clawdd
Maesbury Road Industrial Estate
Oswestry, Shropshire SY10 8NN UK
Phone: +44-1691-676-235
Fax: +44-1691-676-238
E-mail: info@skyjackeurope.co.uk

Skyjack Brasil

Alameda Júpter, 710
Loteamento American Park Empresarial
Indaiatuba, SP, Brasil 13347-653
Tel: +55 19 3936 0132

Rough Terrain Scissor Lifts Service Manual

Table of Contents

Section 1 - Scheduled Maintenance

[Table of Contents](#)

Section 2 - Maintenance Tables

[Table of Contents](#)

Section 3 - Schematics

[Table of Contents](#)

Section 4 - Troubleshooting

[Table of Contents](#)

Section 5 - Procedures

[Table of Contents](#)

The Safety Alert Symbol identifies important safety messages on aerial platforms, safety signs in manuals or elsewhere. When you see this symbol, be alert to the possibility of personal injury or death. Follow the instructions in the safety message.



This Safety Alert Symbol means attention!

Become alert! Your safety is involved.



DANGER

DANGER indicates an imminently hazardous situation which, if not avoided, will result in death or serious injury.



WARNING

WARNING indicates a potentially hazardous situation which, if not avoided, could result in death or serious injury.



CAUTION

CAUTION indicates a potentially hazardous situation which, if not avoided, may result in minor or moderate injury. It may also be used to alert against unsafe practices.

IMPORTANT

IMPORTANT indicates a procedure) essential for safe operation and which, if not followed, may result in a malfunction or damage to the aerial platform.

Section 1 SCHEDULED MAINTENANCE

Table of Contents

Operator’s Responsibility for Maintenance

- Aerial Platform Definition.....6
- Purpose of Equipment.....6
- Use of Equipment.....6
- Manuals.....6
- Operating.....6
- Service & Maintenance.....6
- Operator.....6
- Service Policy and Warranty.....6
- Optional Accessories.....6
- Scope of this Manual.....7
- Operator Safety Reminders.....7
- Electrocution Hazard.....8
- Safety Precautions.....9
- Maintenance and Inspection Schedule.....13
- Owner’s Annual Inspection Record.....13
- Replacement Parts.....13
- Maintenance and Service Safety Tips.....13
- Hydraulic System & Component Maintenance and Repair.....14
- Maintenance Hints.....14

Service and Maintenance

- About this Section.....15
- Service Bulletins.....15
- Maintenance and Inspection.....15
- Maintenance Instructions.....15

Tables

- Table 1.1 Owner’s Annual Inspection Record.....16
- Table 1.2 Maintenance and Inspection Checklist.....17

Scheduled Maintenance

- 1.1 Scheduled Maintenance Inspections.....18
- 1.2 Function Tests.....29

SKYJACK is continuously improving and expanding product features on its equipment, therefore, specifications and dimensions are subject to change without notice.

Aerial Platform Definition

A mobile device that has an adjustable position platform supported from ground level by a structure.

Purpose of Equipment

The SKYJACK Rough Terrain's mid and full size aerial platforms are designed to transport and raise personnel, tools and materials to overhead work areas.

Use of Equipment

The aerial platform is a highly maneuverable, mobile work station. Lifting and driving must be on a flat, level, compacted surface. It can be driven over uneven terrain only when the platform is fully lowered.

Manuals

Operating

The operating manual is considered a fundamental part of the aerial platform. It is a very important way to communicate necessary safety information to users and operators. A complete and legible copy of this manual must be kept in the provided weather-resistant storage compartment on the aerial platform at all times.

Service & Maintenance

The purpose of this is to provide the customer with the servicing and maintenance procedures essential for the promotion of proper machine operation for its intended purpose.

All information in this manual should be read and understood before any attempt is made to service the machine. The updated copy of the manuals are found on the company's website: www.skyjack.com.

Operator

The operator must read and completely understand both this operating manual and the safety panel label located on the platform and all other warnings in this manual and on the aerial platform. Compare the labels on the aerial platform with the labels found within this manual. If any labels are damaged or missing, replace them immediately.

Service Policy and Warranty

SKYJACK warrants each new SJRT series work platform to be free of defective parts and workmanship for the first 24 months. Any defective part will be replaced or repaired by your local SKYJACK dealer at no charge for parts or labor. Contact the SKYJACK Service Department for warranty statement extensions or exclusions.

Optional Accessories

The SKYJACK aerial platform is designed to accept a variety of optional accessories. These are listed under the "Standard and Optional Features" Table of the operating manual. Operating instructions for these options (if equipped) are located in the "Operation" Section of the operating manual.

For non-standard components or systems, contact the SKYJACK Service Department at

 : 44-1691-676-235

 : 44-1691-676-238

Include the model and serial number for each applicable aerial platform.

Scope of this Manual

- a. This manual applies to the KC version of the SJRT Series aerial platform models listed on [Table 2.1](#).

- **Equipment identified** with "KC" meets the requirements for South Korea, i.e., Act 2008-75 and the corresponding KS B ISO 16368:2004 Korean standard.
- b. Operators are required to conform to national, state or territorial/provincial and local health and safety regulations applicable to the operation of this aerial platform.

**WARNING**

Failure to comply with your required responsibilities in the use and operation of the aerial platform could result in death or serious injury!

Operator Safety Reminders

A study conducted by St. Paul Travelers showed that most accidents are caused by the failure of the operator to follow simple and fundamental safety rules and precautions.

You, as a careful operator, are the best insurance against an accident. Therefore, proper usage of this aerial platform is mandatory. The following pages of this manual should be read and understood completely before operating the aerial platform.

Common sense dictates the use of protective clothing when working on or near machinery. Use appropriate safety devices to protect your eyes, ears, hands, feet and body.

Any modifications from the original design are strictly forbidden without written permission from SKYJACK.

Electrocution Hazard

This aerial platform is not electrically insulated when in contact with any energized power line. Maintain a Minimum Safe Approach Distance (MSAD) from energized power lines and parts as listed below. The operator must allow for the platform to sway, rock or sag. This aerial platform does not provide protection from contact with or proximity to an electrically charged conductor.

Per ANSI A92.6-2006 8.10(7)

“The operator shall perform only that work for which he or she is qualified, in compliance with all applicable safety related work practices intended to prevent electric shock covered by the Code of Federal Regulations (CFR) 1910.333. The operator’s level of competence shall be established only by persons qualified to do so. Operators shall maintain the appropriate minimum approach distance (MAD) from energized power lines and parts covered by CFR 1910.333 (c).”

Unqualified persons must maintain a minimum approach distance of 10 feet from any energized power line up to 50 kV. Energized power lines over 50 kV require a greater minimum approach distance to be maintained. Refer to CFR 1910.333.

As per CSA B354.2-01

“The operator shall maintain the minimum safe approach distance (MSAD) from energized conductors at all times in accordance with the authority having jurisdiction.”

**DO NOT USE THE AERIAL PLATFORM AS A GROUND FOR WELDING.
 DO NOT OPERATE THE AERIAL PLATFORM DURING LIGHTNING OR STORMS.
 DO NOT OPERATE THE AERIAL PLATFORM NEAR POWER LINES. MAINTAIN A MINIMUM SAFE APPROACH DISTANCE (MSAD) FROM ENERGIZED POWER LINES.**

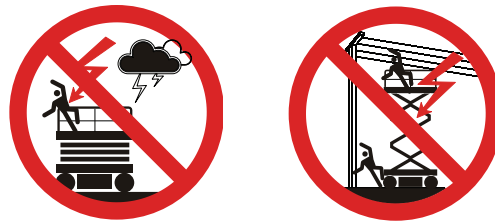

 DANGER Avoid Power Lines	
Minimum Safe Approach Distance	
ANSI/SIA A92.6-2006 & CSA B354.2-01 Requirements	
Voltage Range (Phase to Phase)	Minimum Safe Approach Distance (Feet)
0 to 300V	Avoid Contact
Over 300V to 50KV	10
Over 50KV to 200KV	15
Over 200KV to 350KV	20
Over 350KV to 500KV	25
Over 500KV to 750KV	35
Over 750KV to 1000KV	45
FAILURE TO AVOID THIS HAZARD WILL RESULT IN DEATH OR SERIOUS INJURY!	

60023AD-ANSI

Safety Precautions

Know and understand the safety precautions before going on to next section.



WARNING

Failure to heed the following safety precautions could result in tip over, falling, crushing, or other hazards leading to death or serious injury.

- **KNOW** all national, state or territorial/provincial and local rules which apply to your aerial platform and jobsite.
- **TURN** main power disconnect switch “○” off when leaving the aerial platform unattended. Remove the key to prevent unauthorized use of the aerial platform.
- **WEAR** all the protective clothing and personal safety devices issued to you or called for by job conditions.
- **DO NOT** wear loose clothing, dangling neckties, scarves, rings, wristwatches or other jewelry while operating this lift.



- **AVOID** entanglement with ropes, cords or hoses.



- **AVOID** falling. Stay within the boundaries of the guardrails.



- **DO NOT** raise the aerial platform in windy or gusty conditions.



- **DO NOT** increase the lateral surface area of the platform. Increasing the area exposed to the wind will decrease aerial platform stability. Avoid tenting.



- **DO NOT** drive elevated on a soft or uneven surface.



- **DO NOT** elevate the aerial platform if it is not on a firm, level surface.



- **DO NOT** drive elevated near depressions or holes of any type, loading docks, debris, drop-offs or surfaces that may affect the stability of the aerial platform.

- **IF OPERATION IN AREAS WITH HOLES OR DROP-OFFS IS ABSOLUTELY NECESSARY**, elevated driving shall not be allowed. Position the aerial platform horizontally only with the platform fully-lowered. After ensuring that all 4 wheels or outriggers (if equipped) have contact with a firm, level surface, the aerial platform can be elevated. After elevation, the drive function must not be activated.



- **DO NOT** elevate or drive elevated on a slope. Elevated driving must be done on a firm, level surface.



- **DO NOT** ascend or descend a grade when elevated. When fully-lowered, ascend or descend grades up to maximum rated inclines.

Safety Precautions (Continued)

Know and understand the safety precautions before going on to next section.

- **DO NOT** operate on surfaces not capable of holding the weight of the aerial platform including the rated load, e.g. covers, drains, and trenches.

- **DO NOT** operate an aerial platform that has ladders, scaffolding or other devices mounted on it to increase its size or work height. It is prohibited.



- **DO NOT** exert side forces on aerial platform while elevated.



- **DO NOT** use the aerial platform as a crane. It is prohibited.



- **DO NOT** sit, stand or climb on the guardrails. It is prohibited.



- **DO NOT** climb on scissor arm assembly. It is prohibited.



- **AVOID** overhead obstructions. Be aware of overhead obstructions or other possible hazards around aerial platform when lifting or driving.



- **AVOID** crushing hazards. Be aware of crushing hazards when lifting or driving. Keep all body parts inside the aerial platform.



- **DO NOT** raise the aerial platform while the aerial platform is on a truck, fork lift or other device or vehicle.



- **DO NOT** lower the platform unless the area below is clear of personnel and obstructions.



- **ENSURE** that there are no personnel or obstructions in the path of travel, including blind spots.



- **BE AWARE** of blind spots when operating the aerial platform.

- **DO NOT** use with improperly inflated/damaged tires or wheels.



- **ENSURE** ALL tires are in good condition and lug nuts are properly tightened.

- **DO NOT** alter or disable limit switches or other safety devices.

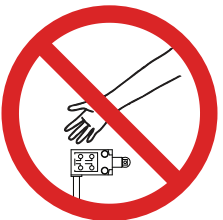

Safety Precautions (Continued)

Know and understand the safety precautions before going on to next section.

- **DO NOT** use the aerial platform without guardrails, locking pins and the entry gate(s) in place.

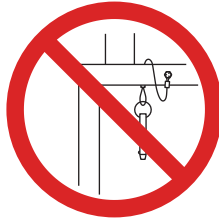

- **DO NOT** attempt to free a snagged platform with lower controls until personnel are removed from the platform.

- **DO NOT** use under influence of alcohol or drugs.



- **DO NOT** position the aerial platform against another object to steady the platform.

- **STUNT** driving and horseplay are prohibited.

- **DO NOT** exceed the rated capacity of the aerial platform.



- **DO NOT** distribute load unevenly.



- **DO NOT** operate if aerial platform is not working properly or if any parts are damaged or worn.



- **DO NOT** leave aerial platform unattended with key in key switch.



Safety Precautions (Continued)

Know and understand the safety precautions before going on to next section.



WARNING

Entering and exiting the aerial platform should only be done using the three points of contact.

- **Use only equipped access openings.**
- **Enter and exit only when the aerial platform is in the fully retracted position.**
- Do use three points of contact to enter and exit the platform. Enter and exit the platform from the ground only. Face the aerial platform when entering or exiting the platform.
- Three points of contact means that two hands and one foot or one hand and two feet are in contact with the aerial platform or the ground at all times during entering and exiting.



WARNING

An operator should not use any aerial platform that:

- **does not appear to be working properly.**
- **has been damaged or appears to have worn or missing parts.**
- **has alterations or modifications not approved by the manufacturer.**
- **has safety devices which have been altered or disabled.**
- **has been tagged or blocked out for non-use or repair.**

Failure to avoid these hazards could result in death or serious injury.

Jobsite Inspection

- Do not use in hazardous locations.
- Perform a thorough jobsite inspection prior to operating the aerial platform, to identify potential hazards in your work area.
- Be aware of moving equipment in the area. Take appropriate actions to avoid collision.

Maintenance and Inspection Schedule

The actual operating environment of the work platform governs the use of the maintenance schedule. The inspection points covered in [Table 1.2](#). Maintenance and Inspection Checklist, indicates the areas of the aerial platform to be maintained or inspected and at what intervals the maintenance and inspections are to be performed.

Owner's Annual Inspection Record

It is the responsibility of the owner to arrange quarterly and annual inspections of the aerial platform. [Table 1.1](#). Owner's Annual Inspection Record is to be used for recording the date of the inspection, owner's name, and the person responsible for the inspection of the work platform.

Replacement Parts

Use only original replacement parts. Parts such as batteries, wheels, railings, etc. with weight and dimensions different from original parts will affect stability of the aerial platform and must not be used without manufacturer's consent.

All replacement tires must be of the same size and load rating as originally supplied tires; to maintain safety and stability of aerial platform.

Consult SKYJACK's Service Department for optional tires specifications and installation.



WARNING

Any unit that is damaged or not operating properly must be immediately tagged and removed from service until proper repairs are completed.

Maintenance and Service Safety Tips

Maintenance and repair should only be performed by personnel who are trained and qualified to service this aerial platform.

All maintenance and service procedures should be performed in a well lighted and well ventilated area.

Anyone operating or servicing this aerial platform must read and completely understand all operating instructions and safety hazards in this manual and operating manual.

All tools, supports and lifting equipment to be used must be of proper rated load and in good working order before any service work begins. Work area should be kept clean and free of debris to avoid contaminating components while servicing.

All service personnel must be familiar with employer and governmental regulations that apply to servicing this type of equipment.

Keep sparks and flames away from all flammable or combustible materials.

Properly dispose of all waste material such as lubricants, rags, and old parts according to the relative law provisions obtaining in the country.

Before attempting any repair work, turn Battery Disconnect Switch to the "OFF" position.

Preventive maintenance is the easiest and least expensive type of maintenance.

Hydraulic System & Component Maintenance and Repair

The following points should be kept in mind when working on the hydraulic system or any component:



WARNING

Escaping fluid from a hydraulic pressure leak can damage your eyes, penetrate the skin and cause serious injury. Use proper personal protection at all times.

1. Any structure has limits of strength and durability. To prevent failure of structural parts of hydraulic components, relief valves which limit pressure to safe operating values are included in the hydraulic circuits.
2. Tolerance of working parts in the hydraulic system is very close. Even small amounts of dirt or foreign materials in the system can cause wear or damage to components, as well as general faulty operation of the hydraulic system. Every precaution must be taken to assure absolute cleanliness of the hydraulic oil.
3. Whenever there is a hydraulic system failure which gives reason to believe that there are metal particles or foreign materials in the system, drain and flush the entire system and replace the filter cartridges. A complete change of oil must be made under these circumstances.
4. Whenever the hydraulic system is drained, check the magnets in the hydraulic reservoir for metal particles. If metal particles are present, flush the entire system and add a new change of oil. The presence of metal particles also may indicate the possibility of imminent component failure. A very small amount of fine particles is normal.
5. All containers and funnels used in handling hydraulic oil must be absolutely clean. Use a funnel when necessary for filling the hydraulic oil reservoir, and fill the reservoir only through the filter opening. The use of cloth to strain the oil should be avoided to prevent lint from getting into the system.
6. When removing any hydraulic component, be sure to cap and tag all hydraulic lines involved. Also, plug the ports of the removed components.
7. All hydraulic components must be disassembled in spotlessly clean surroundings. During disassembly, pay particular attention to the identification of parts to assure proper reassembly. Clean all metal parts in a clean mineral oil solvent. Be sure to thoroughly clean all internal passages. After the parts have been dried thoroughly, lay them on a clean, lint-free surface for inspection.
8. Replace all O-rings and seals when overhauling any component. Lubricate all parts with clean hydraulic oil before reassembly. Use small amounts of petroleum jelly to hold O-rings in place during assembly.
9. Be sure to replace any lost hydraulic oil when completing the installation of the repaired component, and bleed any air from the system when required.
10. All hydraulic connections must be kept tight. A loose connection in a pressure line will permit the oil to leak out or air to be drawn into the system. Air in the system can cause damage to the components and noisy or erratic system operation.

Maintenance Hints

Three simple maintenance procedures have the greatest effect on the hydraulic system performance, efficiency and life. Yet, the very simplicity of them may be the reason they are so often overlooked. What are they? Simply these:

1. Change filters annually. The filters will need to be changed more often depending on the operating conditions. Dirty, dusty, high moisture environments may cause the hydraulic system to be contaminated more quickly.
2. Maintain a sufficient quantity of clean hydraulic oil of the proper type and viscosity in the hydraulic reservoir.
3. Keep all connections tight.

NOTE
Samples of hydraulic oil should be drawn from the reservoir and tested annually. These samples should be taken when the

About this Section

This section contains the maintenance and inspection schedule that is to be performed.

References are made to the procedures in section 5 that outline detailed step-by-step instructions for checks and replacements.

Service Bulletins

Before performing any scheduled maintenance inspection procedure, refer to service bulletins found in our web site: www.skyjack.com for updates related to service and maintenance of this aerial platform.

Maintenance and Inspection

Death or injury can result if the aerial platform is not kept in good working order. Inspection and maintenance should be performed by competent personnel who are trained and qualified on maintenance of this aerial platform.

**WARNING**

Failure to perform each procedure as presented and scheduled may cause death, serious injury or substantial damage.

NOTE

Preventive maintenance is the easiest and least expensive type of maintenance.

- Unless otherwise specified, perform each maintenance procedure with the aerial platform in the following configuration:
 - Aerial platform parked on a flat and level surface
 - Disconnect the battery by turning the main power disconnect switch to the "OFF" position.
- Repair any damaged or malfunction components before operating aerial platform.
- Keep records on all inspections.

Maintenance Instructions

This manual consists of four schedules to be done for maintaining on an aerial platform. Inspection schedule frequency is shown below:

Inspection Schedule





Daily	A
Frequently	A + B
Annually	A + B + C
Bi-annually	A + B + C + D

- Make copies of the maintenance and inspection checklist to be used for each inspection.
- Check the schedule on the checklist for the type of inspection to be performed.
- Place a check in the appropriate box after each inspection procedure is completed.
- Use the maintenance and inspection checklist and step-by-step procedures in section 5 to perform these inspections.
- If any inspection receives a fail, tag and remove the aerial platform from service.
- If any aerial platform component(s) has been repaired, an inspection must be performed again before removing the tag. Place a check in the repair column.

Legend

P = Pass
F = Fail
R = Repaired

Table 1.1 Owner's Annual Inspection Record

										
 Model Number: _____ Serial Number: _____										
*		20__	20__	20__	20__	20__	20__	20__	20__	20__
**										

1000AA

This decal is located on the scissor assembly. It must be completed after an annual inspection has been completed. Do not use the aerial platform if an inspection has not been recorded in the last 13 months.



	Pictorial	Description
*		Inspection Date
**		Inspector Signature



Table 1.2 MAINTENANCE AND INSPECTION CHECKLIST

Serial Number: _____
 Model: _____
 Hourmeter Reading: _____ Name (Printed): _____
 Date: _____
 Time: _____ Signature: _____

Each item shall be inspected using the the appropriate section of the Skyjack service manual.
 As each item is inspected, write the appropriate grade in the box.

INSPECTION FREQUENCY

- DAILY
- FREQUENTLY
- ANNUALLY
- BI-ANNUALLY

- P** - PASS
- F** - FAIL
- R** - REPAIRED

Inspection Schedule	
Daily	A
Frequently*†	A + B
Annually†	A + B + C
Bi-annually†	A + B + C + D

Schedule	P	F	R
Schedule Maintenance Inspections			
Labels	A		
Limit Switches	A, B		
Emergency Lowering Access Rod (If Equipped)	A, B		
Electrical and Control Components			
Main Power Disconnect Switch	A, B		
Base Control Switches	A, B		
Battery	A, B		
Manifolds	A, B, C		
Electrical Panel	A, B		
Tilt (Load) Sensor	A, B		
Hydraulic Tank (Model 92xx)	A, B		
Hydraulic Oil	A, B		
Fuel and Hydraulic Compartment			
Hydraulic Tank (Models 71xx & 88xx)	A, B, C		
Hydraulic Oil (Models 71xx & 88xx)	A, B, C		
Fuel Tank	A, B		
Fuel Leaks	A, B		
Engine Compartment			
Engine Control Console	A, B		
Radiator	A, B, C		
Muffler and Exhaust	A, B		
Engine Tray	A, B		
Hydraulic Pump	A, B		
Engine Air Filter	A, B		
Engine Oil Level	A, B		
Fuel Leaks	A, B		
Platform Assembly			
Lanyard Attachment Anchors	A		
AC Outlet on Platform	A, B		
Platform Control Console	A, B		
Powered Extension Control Console (If Equipped)	A, B		
Lift Mechanism			
Scissor Guards (If equipped)	A, B		
Sliders	A, B		
Maintenance Support	A, B		
Scissor Assembly	A, B		
Scissor Bumpers	A, B		
Lift Cylinder(s)	A, B		

Schedule	P	F	R
Base			
Base Weldment	A, B		
Wheel/Tire Assembly	A, B		
Axles	A, B		
Steer Cylinder Assembly	A, B		
Tie Rod	A, B		
Ladder	A, B		
Outriggers (If Equipped)	A, B		
Manual	A, B		
Function Tests			
Platform Control Console			
Test Emergency Stop	A, B		
Test Lift Enable	A, B		
Test Platform Raising/Lowering	A, B		
Test Enable Trigger Switch	A, B		
Test Steering	A, B		
Test Horn	A, B		
Test Driving	A, B		
Test Brake	A, B		
Test Speed Limit	A, B		
Test Powerdeck Enable (If equipped)	A, B		
Test Extension Platform(s) (If equipped)	A, B		
Base Control Console			
Test Emergency Stop	A, B		
Test Base Lift Enable	A, B		
Test Lower/Neutral/Raise Switch	A, B		
Test Emergency Lowering (Models 71xx, 8831/41 & 9241)	A, B		
Test Emergency Lowering (Model 9250)	A, B		
Test Main Power Disconnect Switch	A, B		
Test Hydraulic Outriggers (If equipped)	A, B		

110AD

- A** - Perform Visual and Daily Maintenance Inspections & Functions Test. Refer to the Operating Manual.
- B** - Perform Scheduled Maintenance Inspection every three months or 150 hrs. Refer to Section 1.0 of this manual.
- C** - Perform Scheduled Maintenance Inspection every year. Refer to Section 1.0 of this manual.
- D** - Perform Scheduled Maintenance Inspection every 2 years. Refer to Section 1.0 of this manual.
- * Perform scheduled inspection every three months or 150 hours.
- † Refer to Skyjack's website @ www.skyjack.com for latest service bulletins prior to performing quarterly or yearly inspection.

Note: Make a copy of this page or visit the Skyjack web site: www.skyjack.com for a printable copy.

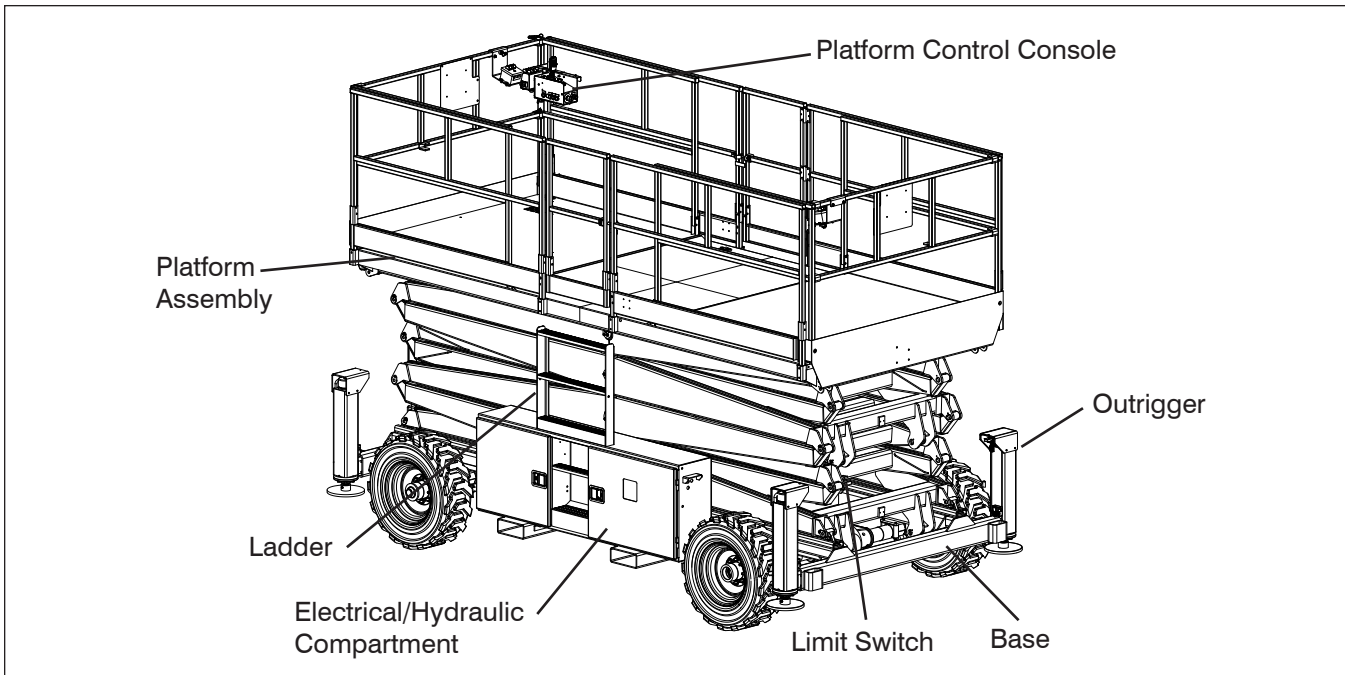

1.1 Scheduled Maintenance Inspections

Begin the scheduled maintenance inspections by checking each item in sequence for the conditions listed in this section.



WARNING

To avoid injury, do not operate an aerial platform until all malfunctions have been corrected.



WARNING

To avoid possible injury, ensure aerial platform power is off during your visual and daily maintenance inspections.

- hydraulic tank filter, fittings, hoses, emergency power unit (if equipped) and base surfaces
- engine compartment fittings, hoses, main pump, and filter
- all hydraulic cylinders
- all hydraulic manifolds
- the underside of the base
- ground area under the aerial platform
- outriggers

Electrical

Maintaining the electrical components is essential to good performance and service life of the aerial platform.

Inspect the following areas for chafed, corroded and loose wires:

- base to platform cables and wiring harness
- engine compartment electrical panel
- engine wiring harness
- hydraulic/electrical wiring harnesses

Hydraulic

Maintaining the hydraulic components is essential to good performance and service life of the aerial platform.

Perform a visual inspection around the following areas:

1.1-1 Labels

Refer to the labels section in this manual and determine that all labels are in place and are legible.

1.1-2 Limit Switches

Detecting limit switch malfunction is essential to safe aerial platform operation. Ensure limit switches are properly secured with no signs of visible damage and movement is not obstructed.

Visually inspect all limit switch located inside the scissor arms and the outrigger assemblies for the following:

- broken or missing actuator arm
- missing fasteners
- loose wiring

1.1-4 Electrical and Control Components

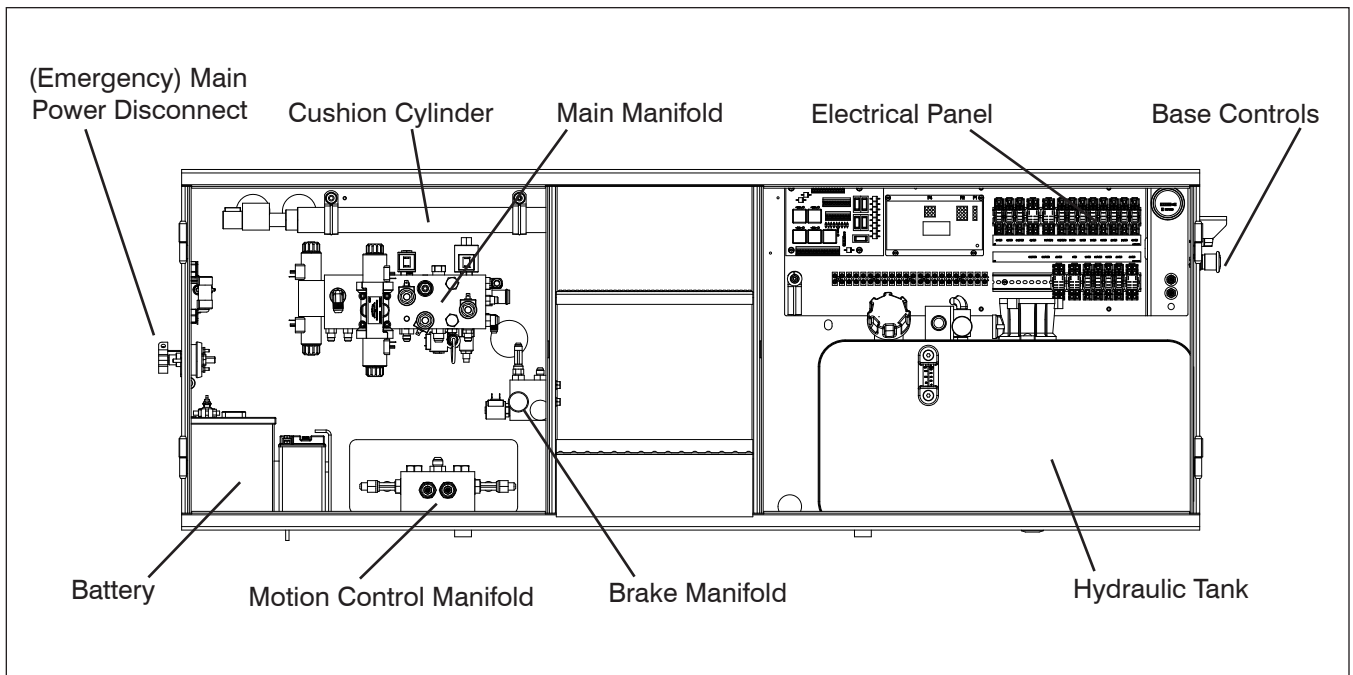

- Ensure all compartment latches are secure and in proper working order.

- **Main Power Disconnect Switch**

- Turn main power disconnect switch to “○” off position.
- Ensure all cables are secure and switch is in proper working condition.

- **Base Control Switches**

- Ensure there are no signs of visible damage and all switches are in their neutral positions.

- **Battery**

Proper battery condition is essential to good performance and operational safety. Improper fluid levels or damaged cables and connections can result in component damage and hazardous conditions.



WARNING

Explosion hazard. Keep flames and sparks away. Do not smoke near batteries.



WARNING

Battery acid is extremely corrosive - Wear proper eye and facial protection as well as appropriate protective clothing. If contact occurs, immediately flush with cold water and seek medical attention.

1. Check battery case for damage.
2. Clean battery terminals and cable ends thoroughly with a terminal cleaning tool or wire brush.
3. Ensure all battery connections are tight.
4. If applicable, check battery fluid level. If plates are not covered by at least 13 mm of solution, add distilled or demineralized water.
5. Replace battery if damaged or incapable of holding a lasting charge.



WARNING

Use original or manufacturer-approved parts and components for the aerial platform.

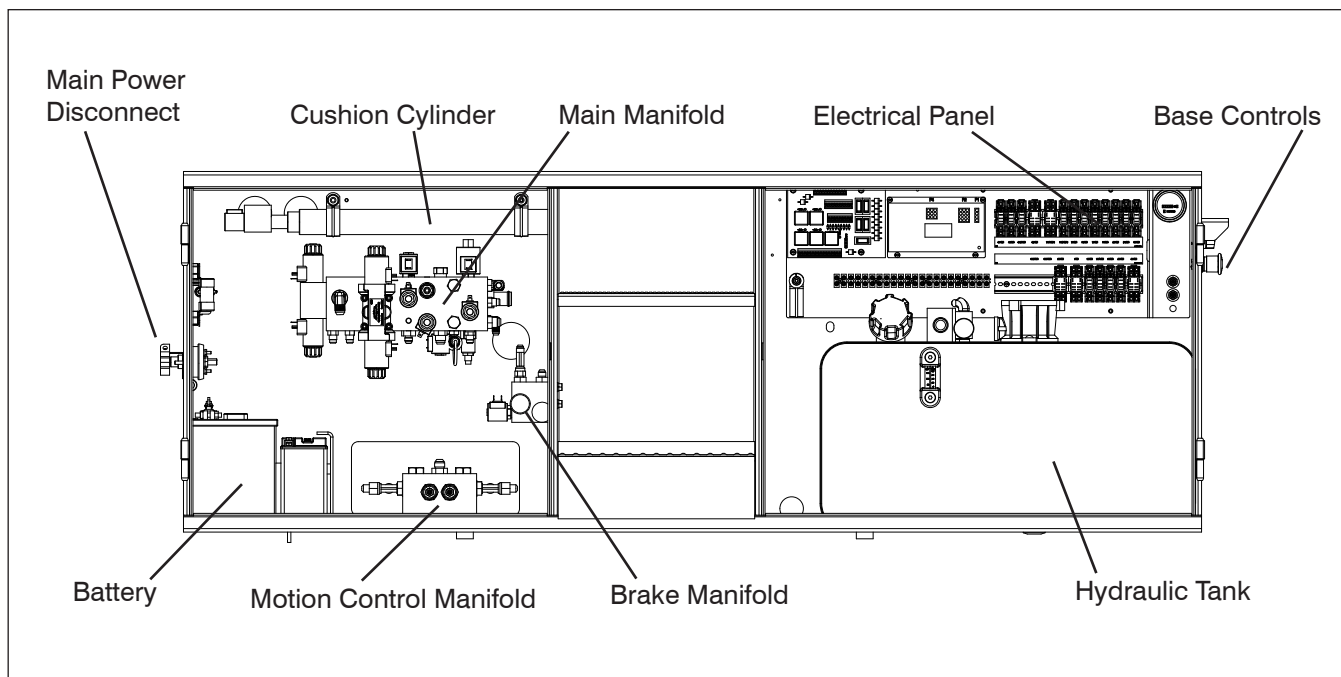

- **Manifolds**
 - Ensure all fittings and hoses are properly tightened and there is no evidence of hydraulic leakage.
 - Ensure there are no loose wires or missing fasteners.
- **Electrical Panel**
 - Ensure panel is properly secured and there is no visible damage.
 - Ensure there are no loose wires or missing fasteners.
- **Load/Tilt Sensor**
 - Ensure load/tilt sensor is properly secure and there is no visible damage.
- **Hydraulic Tank**
 - Ensure hydraulic filler cap is secure.
 - Ensure tank shows no visible damage and no evidence of hydraulic leakage.

- **Hydraulic Oil**
 - Ensure platform is fully lowered, and outriggers retracted, and then visually inspect the sight gauge located on the side of the hydraulic oil tank. Check oil level against label that indicates minimum and maximum oil levels.

C - Annual Inspection

- [Refer to Section 1 - Hydraulic System & Component Maintenance and Repair](#)

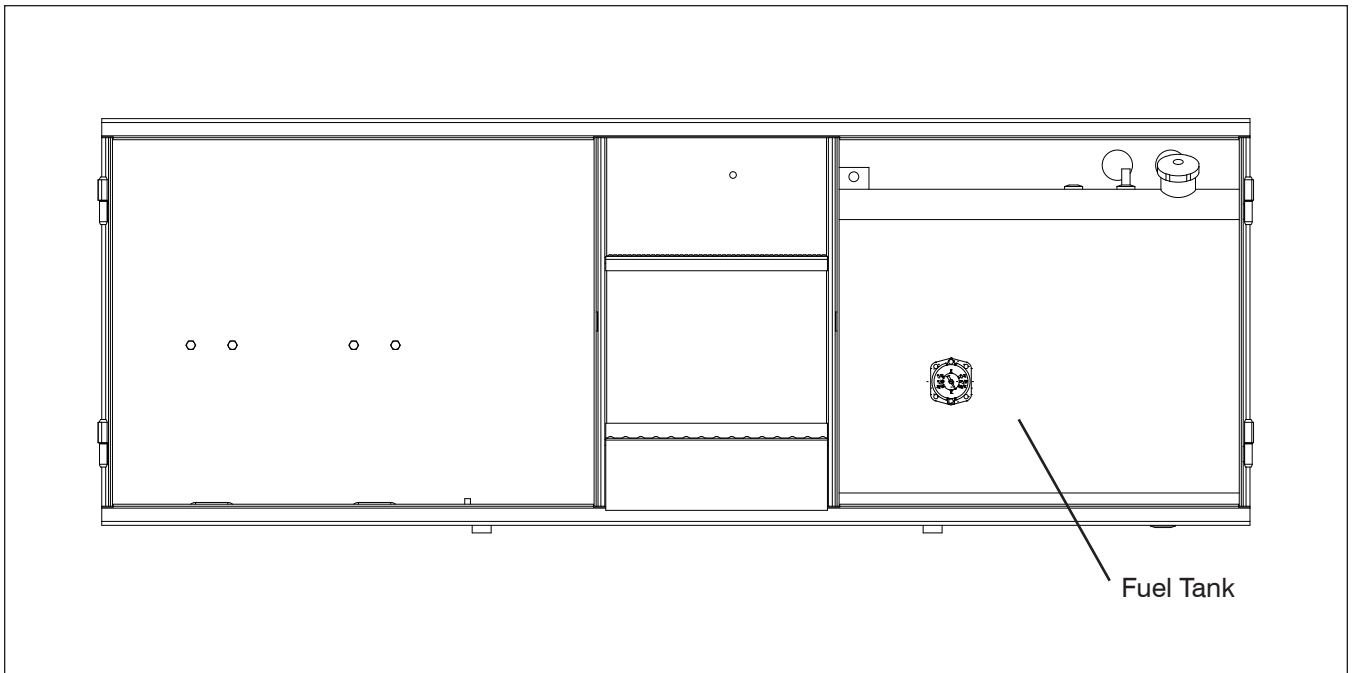

1.1-5 Fuel and Hydraulic Compartment

- Ensure all compartment latches are secure and in proper working order.

- **Fuel Tank**

IMPORTANT

Before using your aerial platform ensure there is enough fuel for expected use.

- Ensure fuel filler cap is secure.
- Ensure tank shows no visible damage and no evidence of fuel leakage.

- **Fuel Leaks**

- Ensure that there are no fuel leaks.



DANGER

Engine fuels are combustible. Inspect the aerial platform in an open, well-ventilated area away from heaters, sparks and flames. Always have an approved fire extinguisher within easy reach.

- Ensure fuel tank, hoses and fittings show no visible damage and no evidence of fuel leakage.

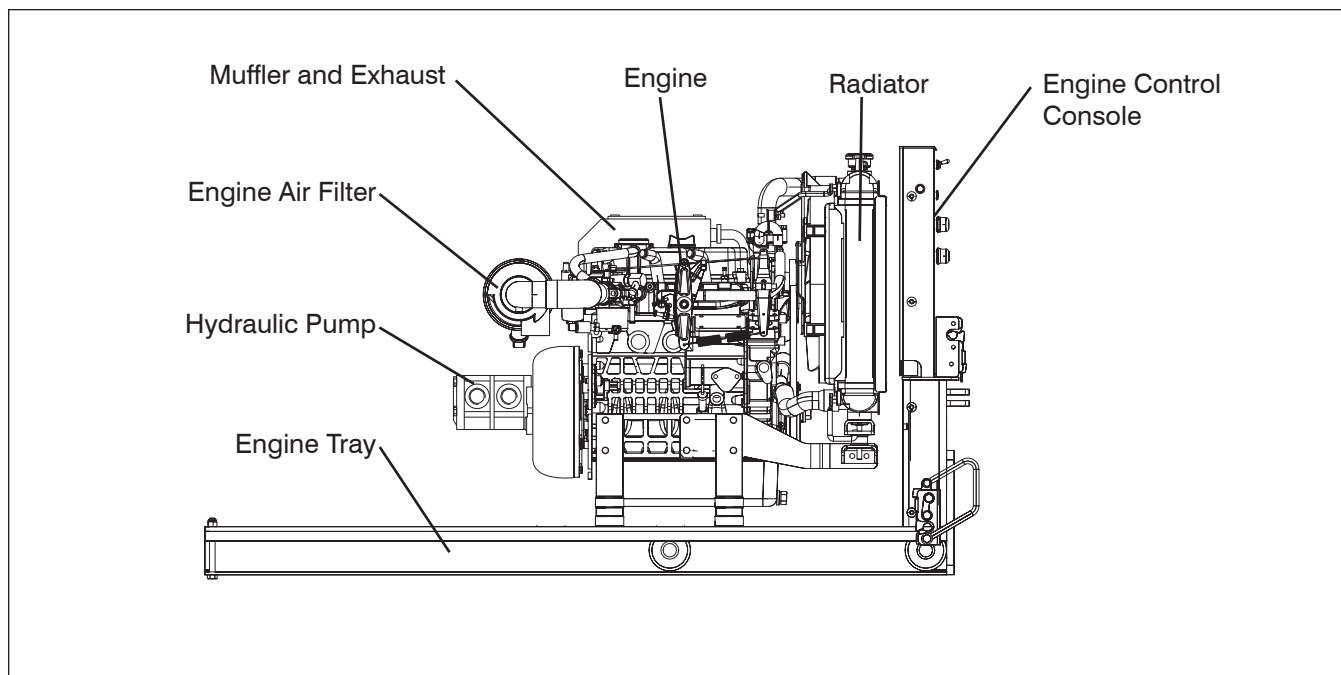

1.1-6 Engine Compartment



WARNING

Beware of hot engine components.

1. Pull on the two latches to pull out engine compartment.

- **Engine Control Console**
 - Ensure muffler and exhaust system are properly secured, with no evidence of damage.
- **Radiator**
 - Ensure radiator is secure.
 - Ensure there are no loose or missing parts and there is no visible damage.
 - Check coolant level and add as needed.

C - Annual Inspection

- For recommend coolant change, refer to engine manual.

- **Muffler and Exhaust**
 - Ensure muffler and exhaust system are properly secured, with no evidence of damage.
- **Engine Tray**
 - Ensure there are no loose or missing parts and no visible damage to the engine tray. Ensure that both tray-securing bolts are in place.
- **Hydraulic Pump**
 - Ensure there are no loose or missing parts and there is no visible damage.
 - Ensure all bolts are properly tightened.
 - Ensure all fittings and hoses are properly tightened and there is no evidence of hydraulic leakage.

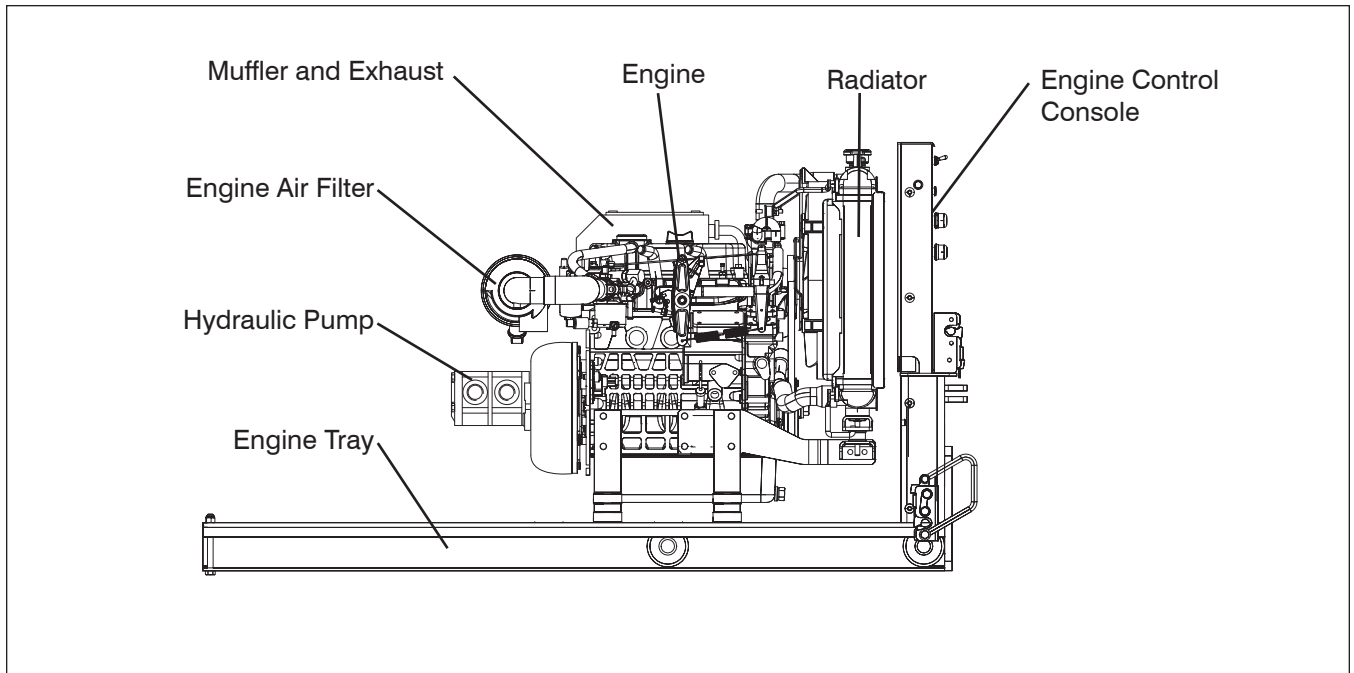

- **Engine Air Filter**
 - Ensure there are no loose or missing parts and there is no visible damage.

B - Frequent Inspection

- For engine air filter maintenance procedure, refer to engine manual.

C - Annual Inspection

- For engine air filter replacement procedure, refer to engine manual.

- **Engine Oil Level**
 - Maintaining the engine components is essential to good performance and service life of the aerial platform.

Check oil level on dipstick

- Oil level should be between the "L" and "H" marks.

B - Frequent Inspection

- For recommend oil change, refer to engine manual

-

- **Fuel Leaks**
 - Ensure there are no fuel leaks.



DANGER

Engine fuels are combustible. Inspect the aerial platform in an open, well-ventilated area away from heaters, sparks and flames. Always have an approved fire extinguisher within easy reach.

- Ensure fuel pump, fuel filter, hoses and fittings show no visible damage and no evidence of fuel leakage.
2. Push in engine compartment until the two latches lock to base.

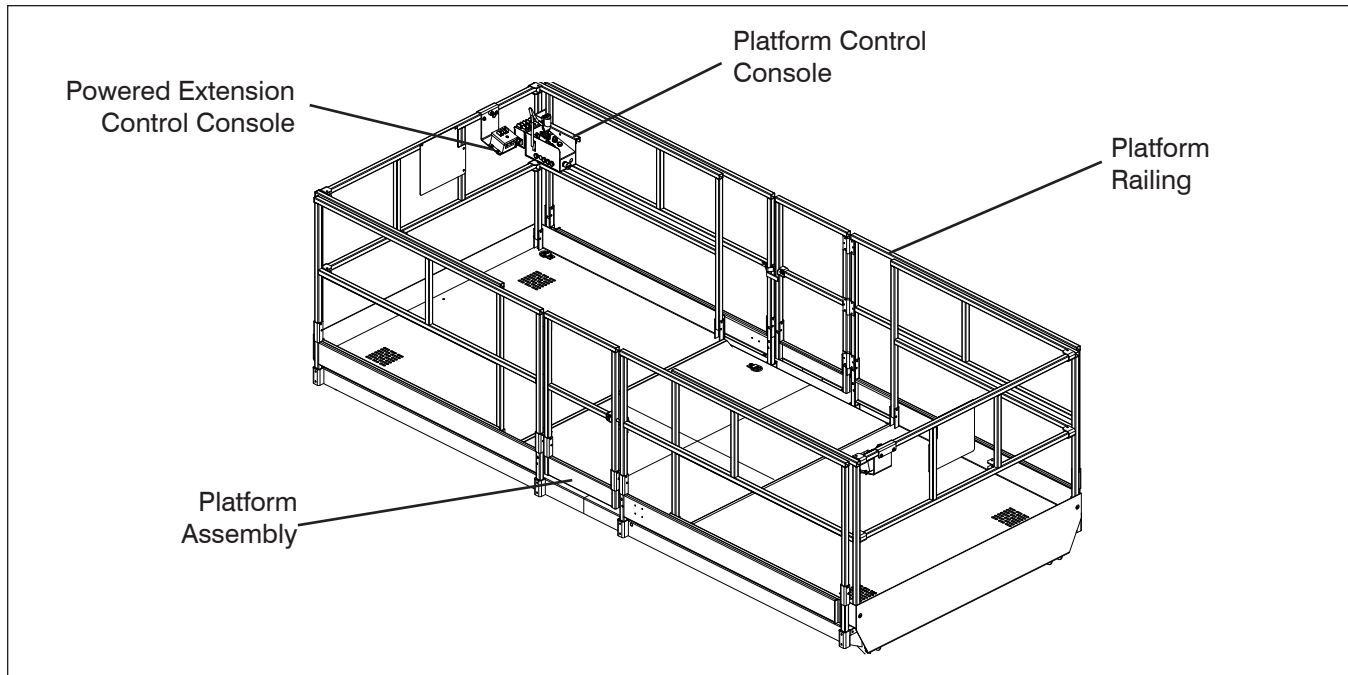

1.1-7 Platform Assembly



WARNING

Ensure that you maintain three points of contact to mount/dismount platform.

1. Use the ladder of aerial platform to access platform.
2. Close the gate.
 - Ensure there are no loose or missing parts and there is no visible damage.
 - Ensure all fasteners are securely in place.
 - Ensure all railings are properly positioned and secured.
 - Ensure gate is in good working order.
- **Lanyard Attachment Anchors**
 - Ensure attachment rings are secure and have no visible damage.
- **AC Outlet on Platform**
 - Ensure outlet has no visible damage and free from dirt or obstructions.

• **Platform Control Console**

- Ensure all switches and controller are returned to neutral and are properly secured.
- Ensure there are no loose or missing parts and there is no visible damage.

• **Powered Extension Control Console**

- Ensure all switches are returned to neutral and are properly secured.
- Ensure there are no loose or missing parts and there is no visible damage.



WARNING

Ensure that you maintain three points of contact to mount/dismount platform.

3. Use the ladder to dismount from platform.

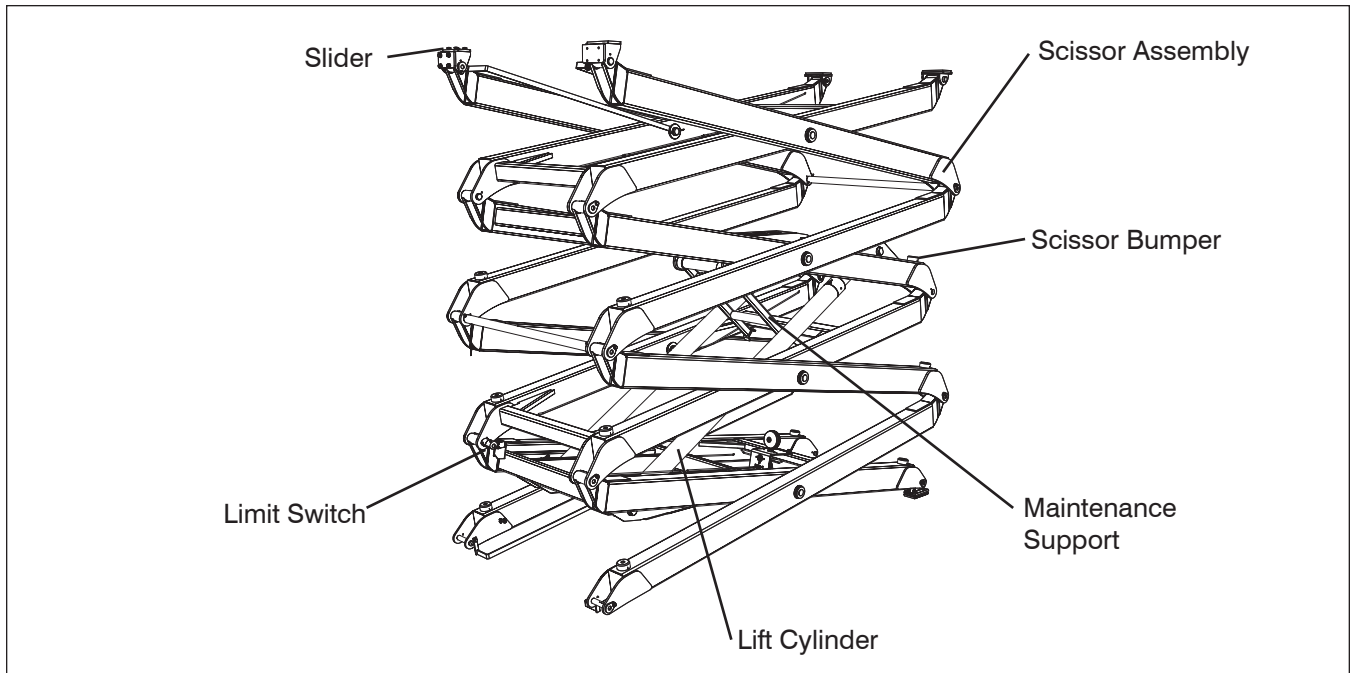

1.1-8 Lifting Mechanism

- **Scissor Guards (If equipped)**
 - Ensure there are no loose or missing parts and there is no visible damage.
- **Sliders**
 - Ensure sliders are secure and there is no visible damage.
 - Ensure sliders' path of travel are free from dirt and obstructions.
- 1. Raise the platform until there is adequate clearance to swing down the maintenance support.
- **Maintenance Support**
 - Ensure maintenance support is properly secured and shows no visible damage.
- **Scissor Assembly**
 - Ensure scissor assembly shows no visible damage and no signs of deformation in weldments.
 - Ensure all pins are properly secured.
 - Ensure cables and wires are properly routed and shows no signs of wear and/or physical damage.
- **Scissor Bumpers**
 - Ensure bumpers are secure and shows no sign of visible damage.
- **Scissor Pin Inspection**
 - Complete a structural inspection of the scissor pin connections, looking for indicators of pin and/or scissor arm damage. These indicators include, but are not limited to:
 - Noise coming from binding/seized pins
 - Rust forming near pin joint
 - Cracks in welds or in surrounding metal
 - Evidence of metal dust or shavings from wearing components
 - Broken/missing pin retainer bolts
 - Broken/missing pin retainers
 - Rotated pin
 - Elongation/enlargement of pin hole

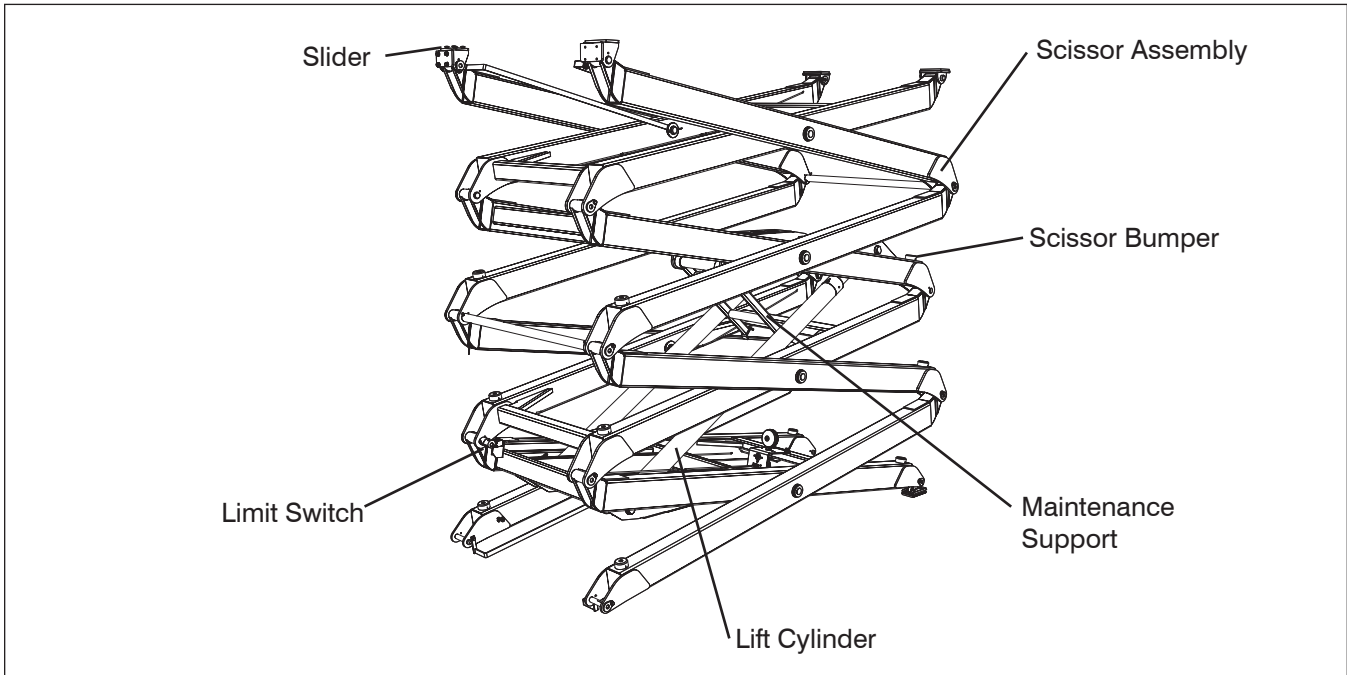

Examples of pivot pin connections with no damage:

- No rust
- Pin has not rotated
- Area is clear of dust/metal shavings
- Pin retainer/retainer bolts are in place

Pin retainer bolts in place

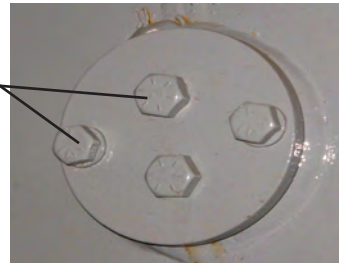

Center pin pivot - Outer

Pin retainer in place

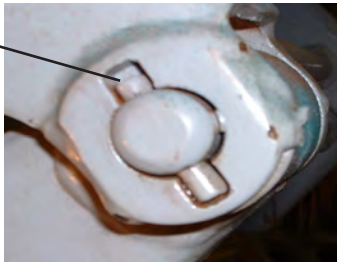

No rust. Pin has not rotated. Area is clean of dust/metal shavings



Center pin pivot - Middle

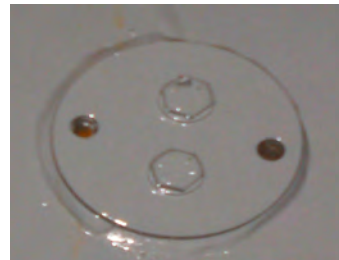

Center pin pivot - Inner

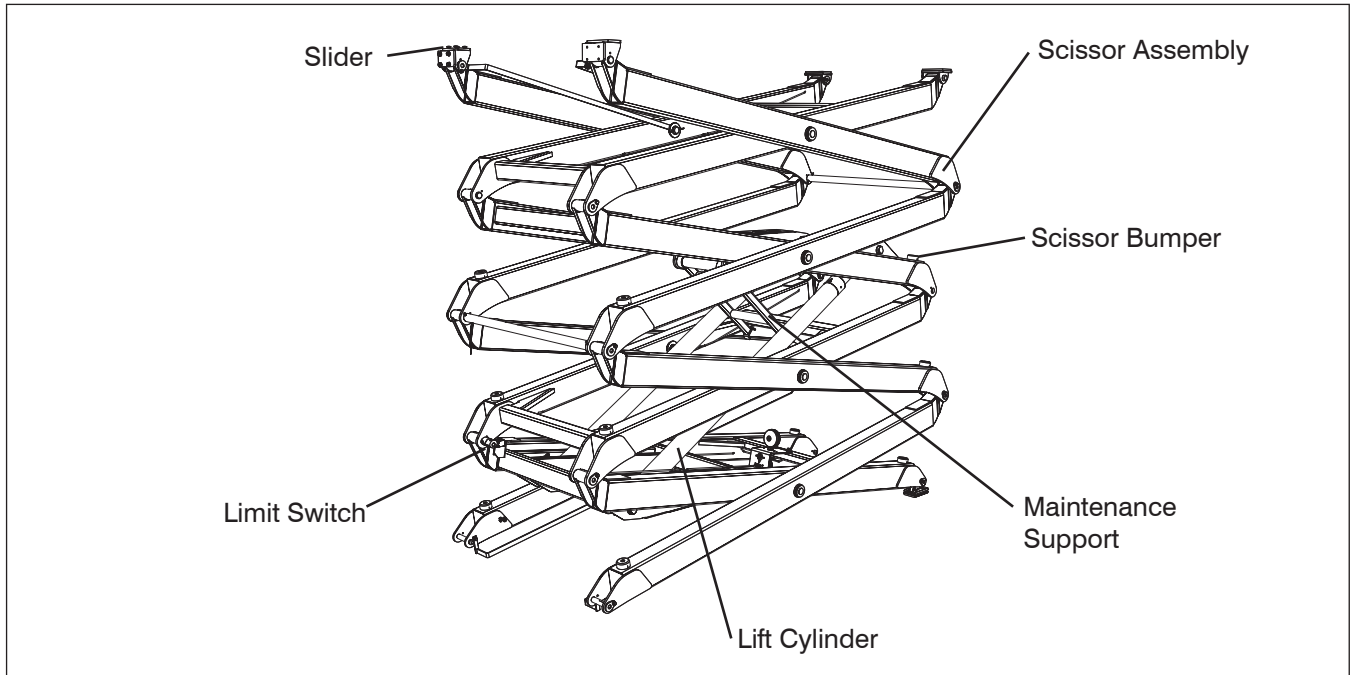

Examples of damaged pin connections:

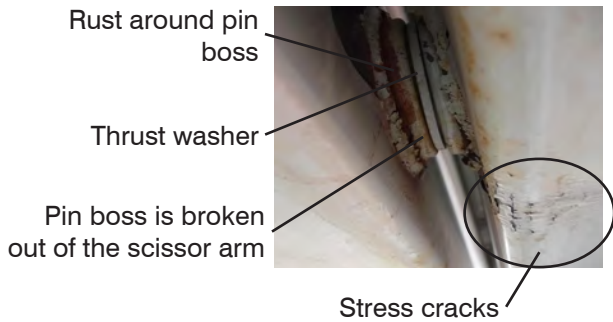
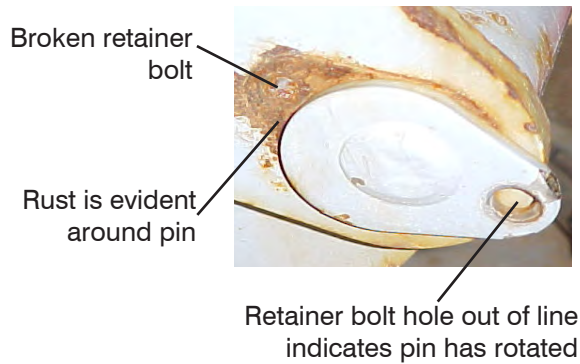

• **Lift Cylinder(s)**

- Ensure each lift cylinder is properly secured, there are no loose or missing parts and there is no evidence of damage.
 - Ensure all fittings and hoses are properly tightened and there is no evidence of hydraulic leakage.
2. Raise the platform until there is adequate clearance to swing up the maintenance support into storage bracket.
 3. Fully lower the platform.



WARNING

Any units showing the above listed and/or depicted signs of damage should be immediately removed from service and repaired by a qualified technician.

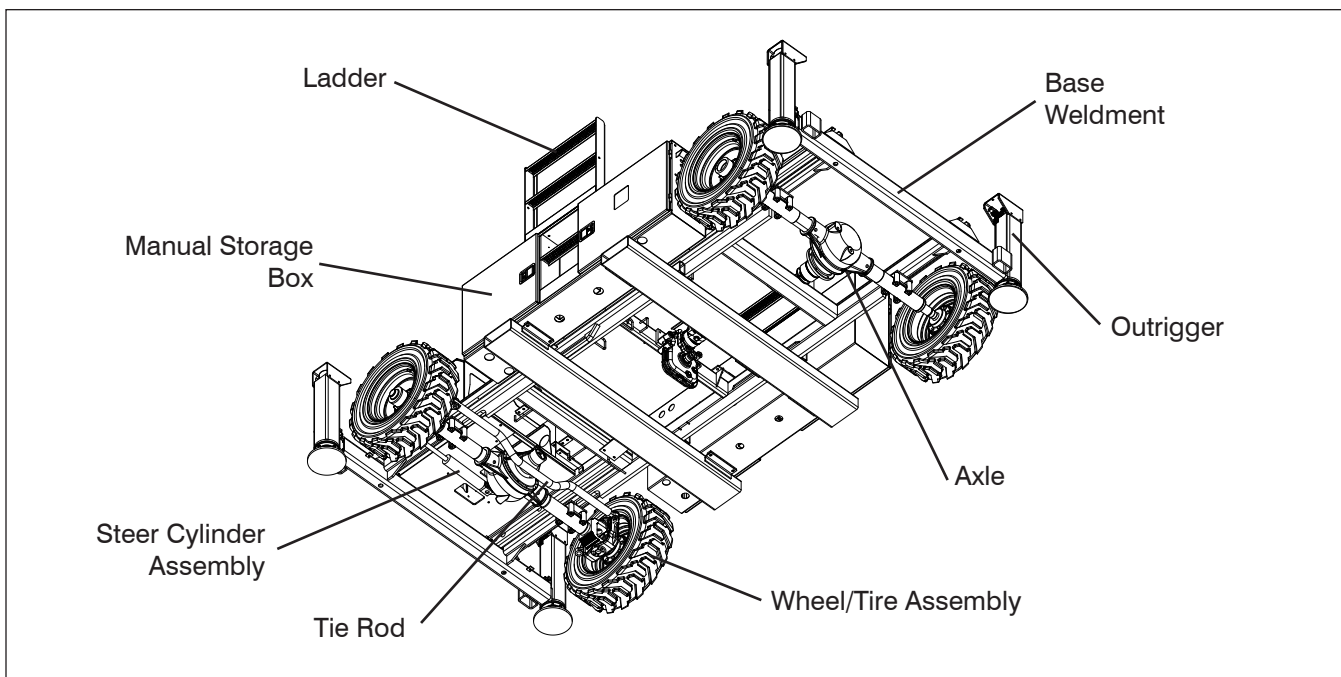

1.1-9 Base

- **Base Weldment**
 - Ensure there are no visible cracks in welds or structure and there are no signs of deformation.
- **Wheel/Tire Assembly**

The aerial platform is equipped with foam-filled tires. Tire and/or wheel failure could result in an aerial platform tipover. Component damage may also result if problems are not discovered and repaired in a timely fashion.

 - Check all tire treads and sidewalls for cuts, cracks, punctures and unusual wear.
 - Check each wheel for damage and cracked welds.
 - Check each lug nut for proper torque to ensure none are loose.

Refer to [Table 2.4](#) for wheel/tire specifications.

- **Drive Axles**
 - Ensure axles are properly secured, there are no loose or missing parts, all fittings and hoses are properly tightened and there is no evidence of hydraulic leakage.

- **Steer Cylinder Assembly**
 - Ensure steer cylinder assembly is properly secured, there are no loose or missing parts, all fittings and hoses are properly tightened and there is no evidence of hydraulic leakage.
- **Tie Rod**
 - Ensure there are no loose or missing parts, tie rod end studs are locked and there is no visible damage.
- **Ladder**
 - Ensure there are no loose or missing parts and there is no visible damage.
- **Outriggers**
 - Ensure there are no loose or missing parts and there is no visible damage.

1.1-10 Manuals

Ensure a copy of operating manual, and other important documents are enclosed in manual storage box.

- Check to be sure manual storage box is present and in good condition.
- Ensure manuals are legible and in good condition.
- Always return manuals to the manual storage box after use.

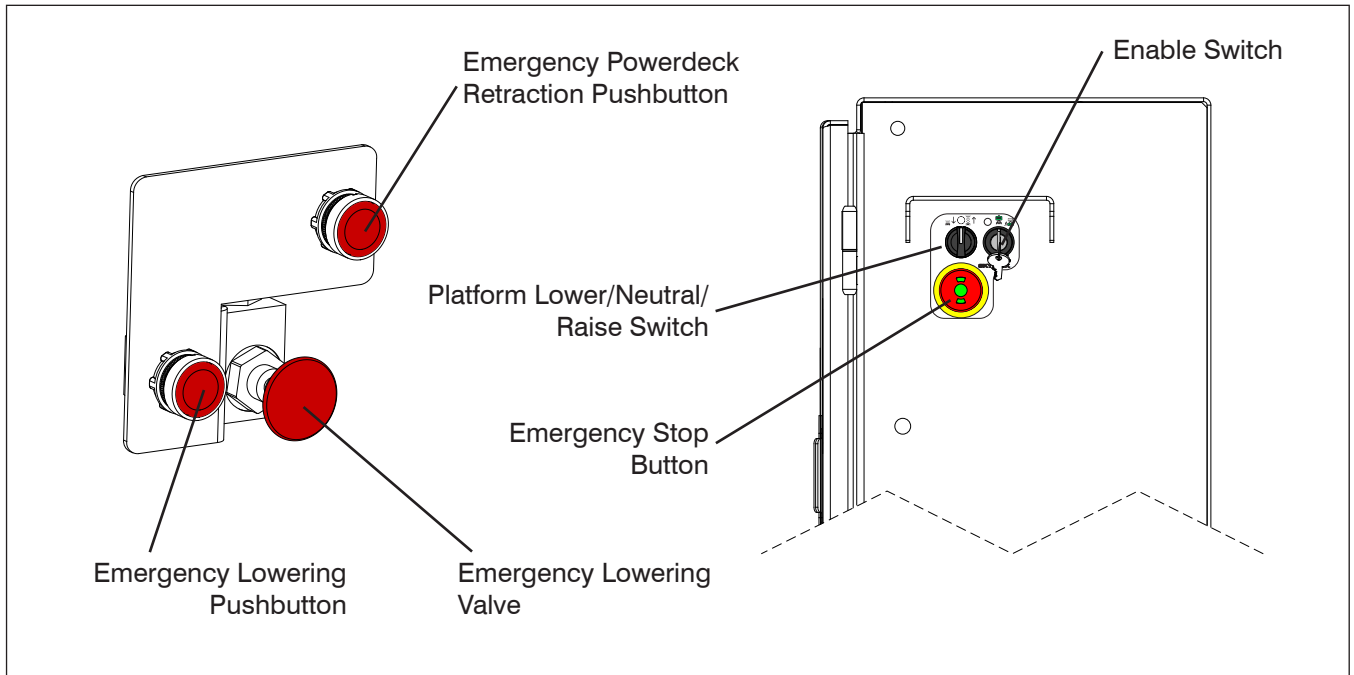

1.2 Function Tests

Function tests are designed to discover any malfunctions before aerial platform is put into service. The operator must understand and follow step-by-step instructions to test all aerial platform functions.



WARNING

Never use a malfunctioning aerial platform. If malfunctions are discovered, aerial platform must be tagged and placed out of service. Repairs to aerial platform may only be made by a qualified service technician.

After repairs are completed, operator must perform a pre-operation inspection and a series of function tests again before putting aerial platform into service.

Prior to performing function tests, be sure to read and understand Section 2.10 - Start Operation of the operating manual.

1.2-1 Test Main Power Disconnect Switch

1. On the side of hydraulic/electrical compartment, turn main power disconnect switch to "O" off position.
Result: Engine should shut down and aerial platform functions should not operate.

1.2-2 Base Control Console



WARNING

Ensure that you maintain three points of contact when using the ladder to mount/dismount platform.

1. Use the ladder of aerial platform to access platform.
2. Close the gate.
3. On platform control console, pull out "E" emergency stop button.
4. Insert key into off/lift/drive key switch and select "↑" lift position.
5. Select low/high throttle switch to "L" low throttle position.



CAUTION

Do not start the engine in the high throttle position.

6. Use the ladder to dismount from platform.
7. Turn main power disconnect switch to "I" on position.

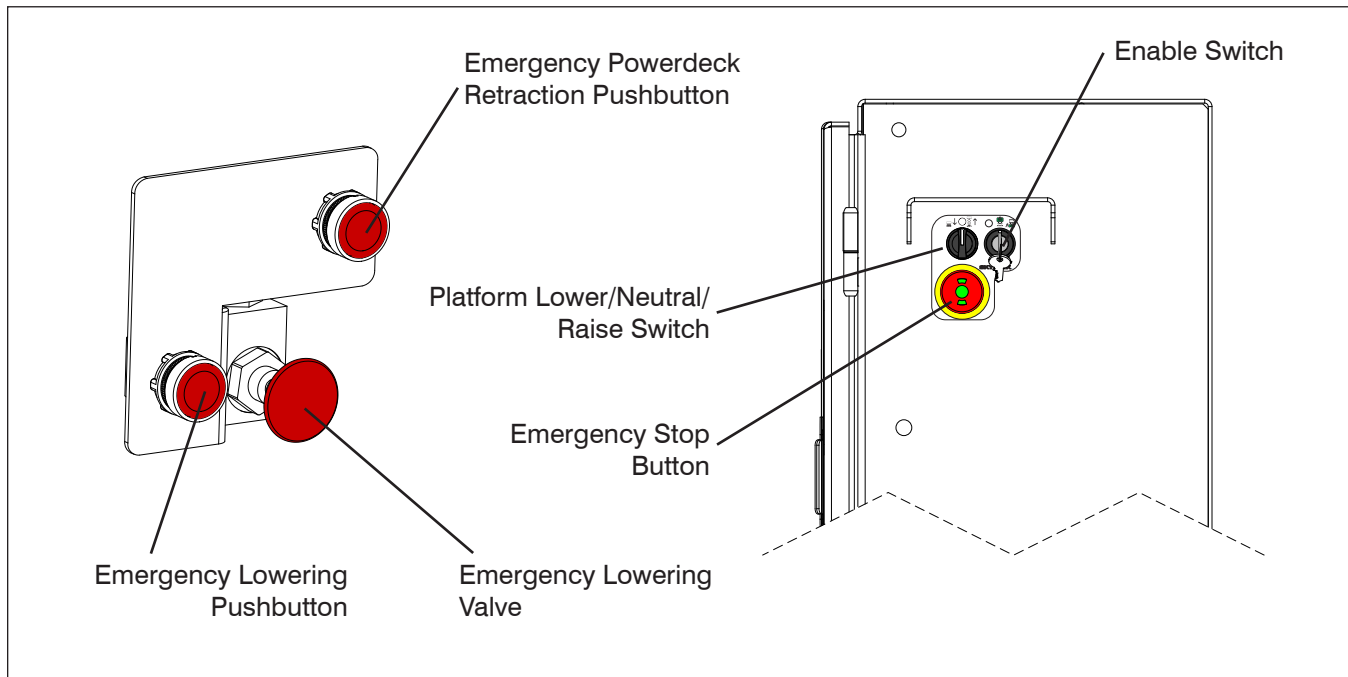

8. On base control console, pull out “” emergency stop button. A beeping sound should be audible and light should come on.





WARNING



If beeping sound is not audible and light does not come on, aerial platform must be tagged and placed out of service.

9. On engine control console, select off/on/start switch to “I” on position.



10. To start the engine:

- If diesel engine is cold, select and hold “” glow plug switch for 15 to 20 seconds or until indicator light goes off. Depress and hold “” engine start switch to start the engine.
- If engine is warm, depress and hold “” engine start switch to start the engine.





• **Test Emergency Stop**

1. Push in “” emergency stop button.
Result: Engine should shut down and aerial platform functions should not operate.
2. Pull out “” emergency stop button and restart engine.

• **Test Base Lift Enable**

1. On base control console, select and hold lower/neutral/raise switch “” to raise position without selecting “” enable switch.
Result: Platform should not rise.

• **Test Lower/Neutral/Raise Switch**

1. On base control console, select and hold “” enable switch and “” raise the platform with lower/neutral/raise switch.
Result: Platform should rise.
2. Select and hold “” enable switch and fully “” lower the platform with lower/neutral/raise switch.
Result: Platform should fully lower.

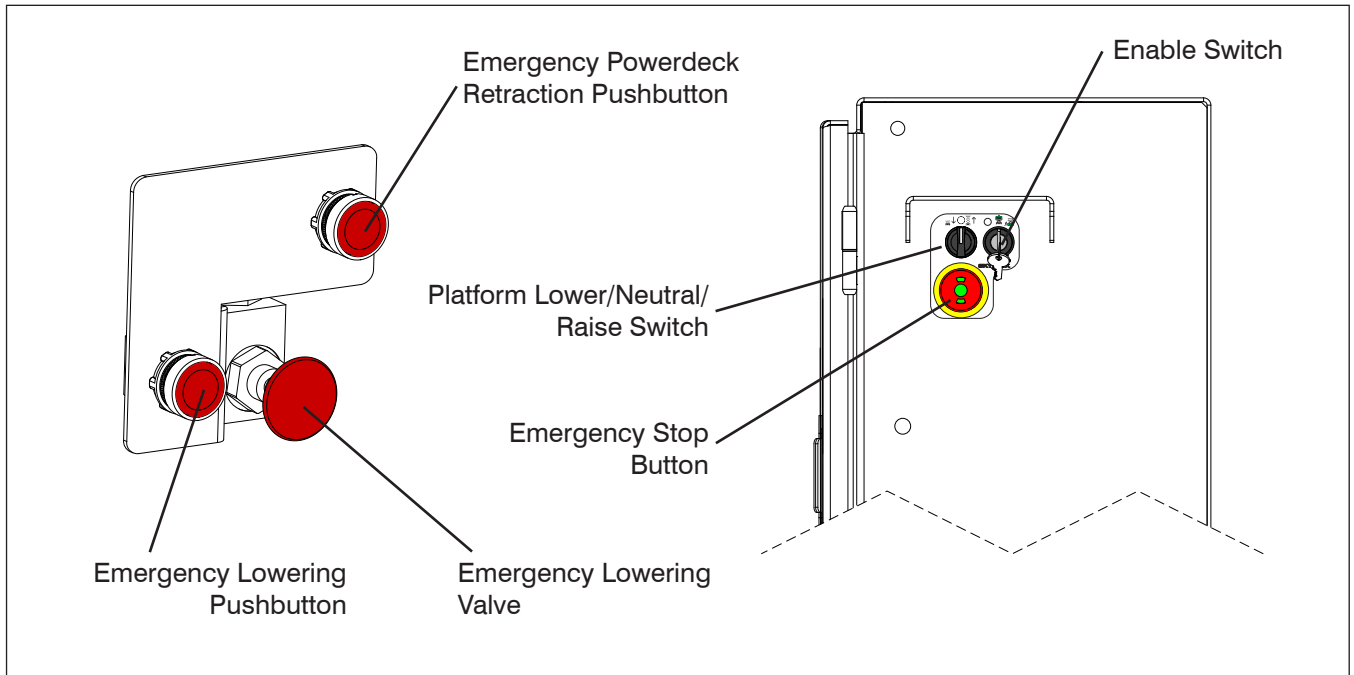

- **Test Emergency Lowering**



**WARNING**

Be aware of overhead obstructions or other possible hazards around the aerial platform when lifting.

1. Raise the platform to an approximate height of 4 meters.
2. In hydraulic/electrical compartment, depress and hold emergency lowering pushbutton to activate the auxiliary lowering valves. Pull out and hold the emergency lowering valve to fully lower platform.

Result: The platform should fully lower.

- **Test Powered Extension Platform Emergency Retraction Switch**

1. Extend both powered extension platforms to about 0.5 meter.
2. Push in “” emergency stop button to shut down the engine.
3. Pull out “” emergency stop button.

**WARNING**

Ensure that you maintain three points of contact when using the ladder to mount/dismount platform.

4. Use the ladder to dismount from platform.
5. On hydraulic/electric tray, push the emergency powered extension platform retraction switch.

Result: Extension platforms should retract.

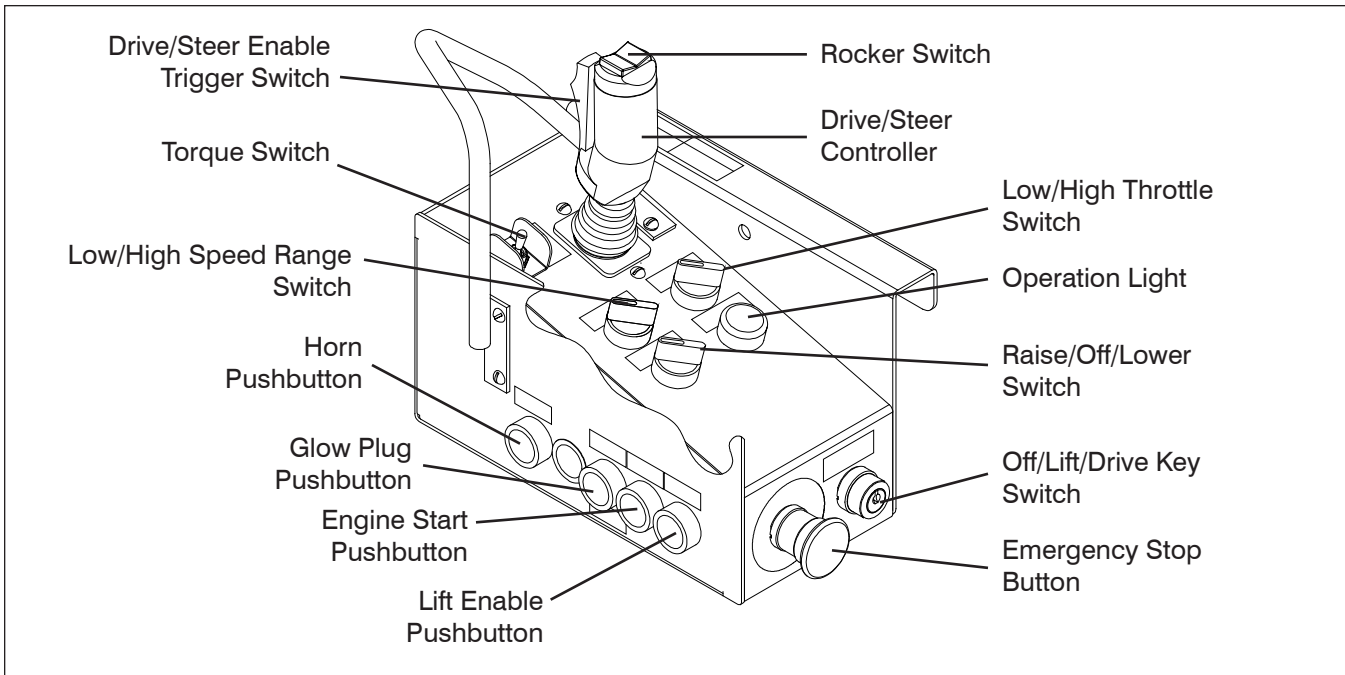



1.2-1 Platform Control Console

1. Turn main power disconnect switch to “|” on position.
2. On base control console, pull out “” emergency stop button.
3. On engine control console, select off/on/start switch to “|” on position.



WARNING

Ensure that you maintain three points of contact when using the ladder to mount/dismount platform.

4. Use the ladder of aerial platform to access platform.
5. Close the gate.
6. Insert key into off/lift/drive key switch and select “↑
↓” lift position.
7. On platform control console, pull out “” emergency stop button. A beeping sound should be audible and light should come on.



WARNING



If beeping sound is not audible and light does not come on, aerial platform must be tagged and placed out of service.

8. Select low/high throttle switch to “” low throttle position.



CAUTION

Do not start the engine in the high throttle position.

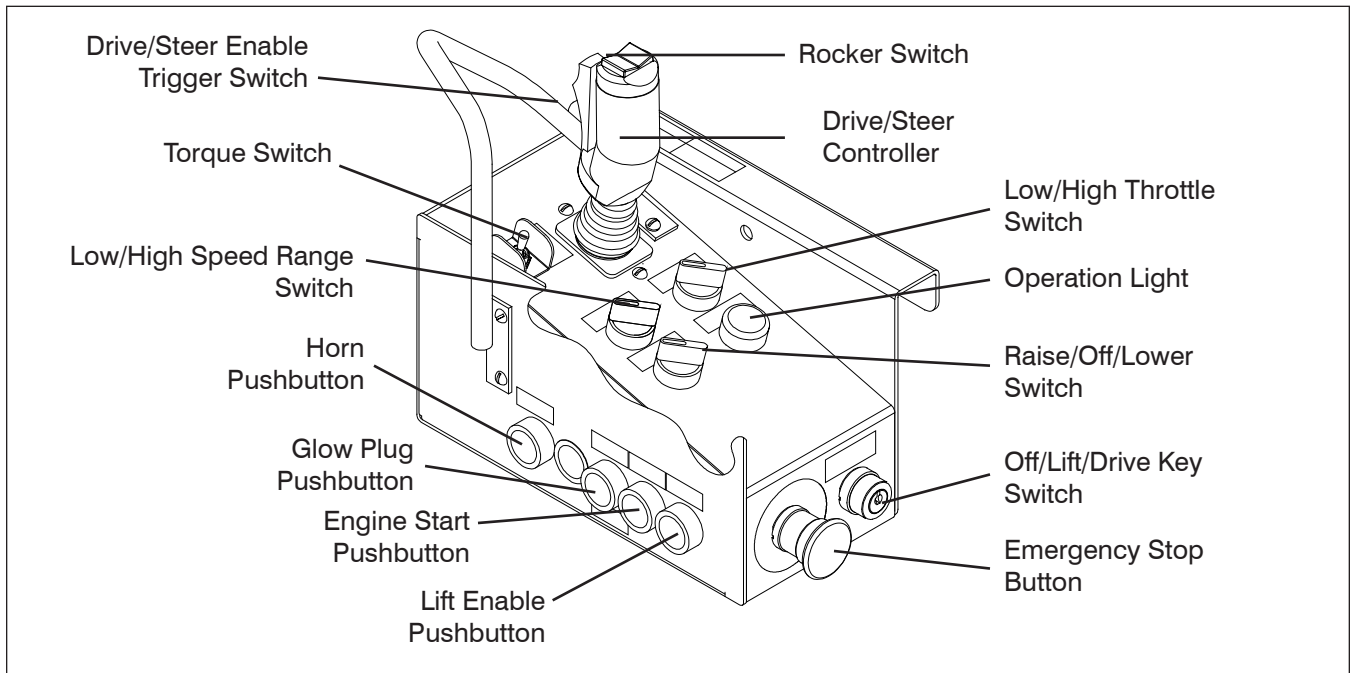

9. To start the engine:
 - If diesel engine is cold, select and hold “” glow plug pushbutton for 15 to 20 seconds or until indicator light goes off. Depress and hold “” engine start pushbutton to start the engine.
 - If engine is warm, depress and hold “” engine start pushbutton to start the engine.



- **Test Emergency Stop**

1. Push in “” emergency stop button.
Result: Engine should shut down and aerial platform functions should not operate.

- **Test Lift Enable**





1. Pull out “” emergency stop button.
2. Restart the engine.
3. Select and hold raise/off/lower switch to “” raise position without pressing lift “” enable pushbutton.
Result: Platform should not rise.

- **Test Platform Raising/Lowering**



WARNING

Be aware of overhead obstructions or other possible hazards around the aerial platform when lifting.

1. Press and hold lift “” enable pushbutton, then select and hold raise/off/lower switch to “” raise position and raise the platform to an approximate height of 0.5 meter. Release switch to stop.
Result: Platform should rise.
2. Press and hold lift “” enable pushbutton, then select and hold raise/off/lower switch to “” lower position and lower the platform fully. Release switch to stop.
Result: Platform should lower.

- **Test Enable Trigger Switch**

1. Ensure outriggers are fully retracted.
2. Ensure path of intended motion is clear.

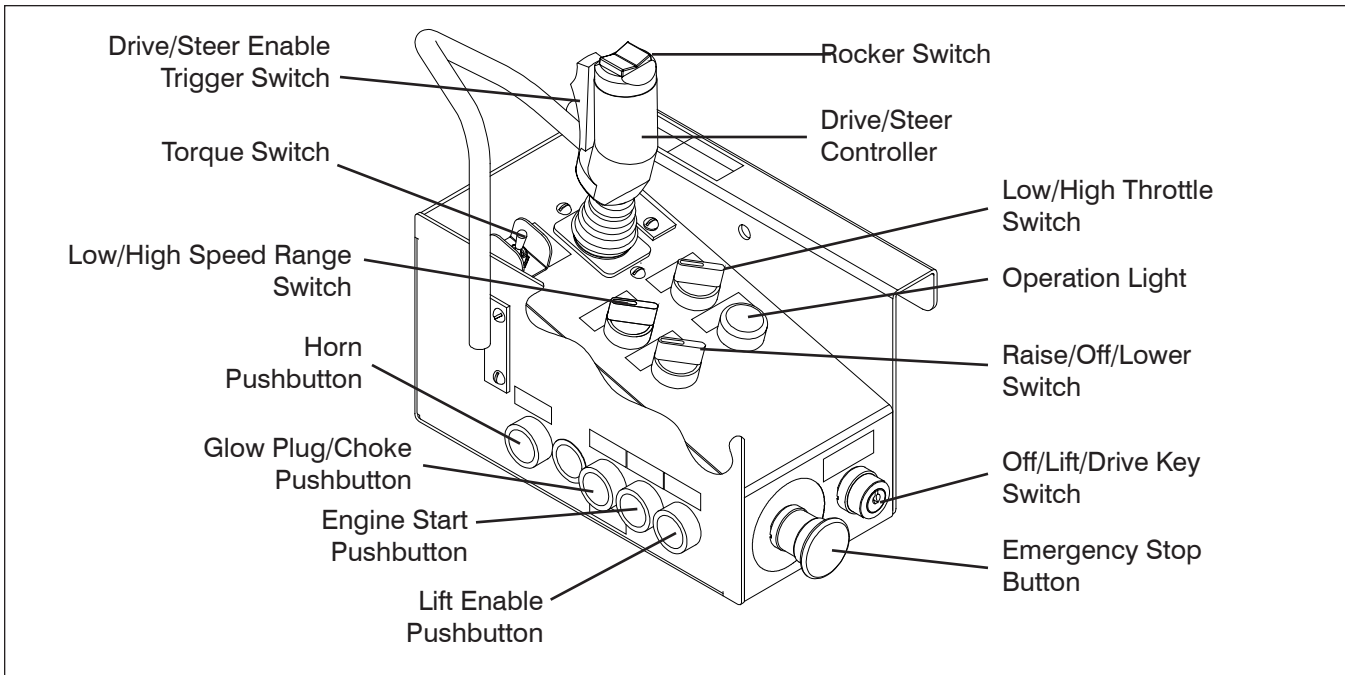

3. Select off/lift/drive key switch to “” drive position.

4. Without activating “” enable trigger switch, attempt to drive and steer the aerial platform.
Result: Drive and steer functions should not operate.

• **Test Steering**

1. Activate and hold enable trigger switch, and then press rocker switch on top of controller to “” left and “” right.
Result: Steer wheels should turn left and right.

• **Test Horn**

1. Push “” horn pushbutton.
Result: Horn should sound.

• **Test Driving**



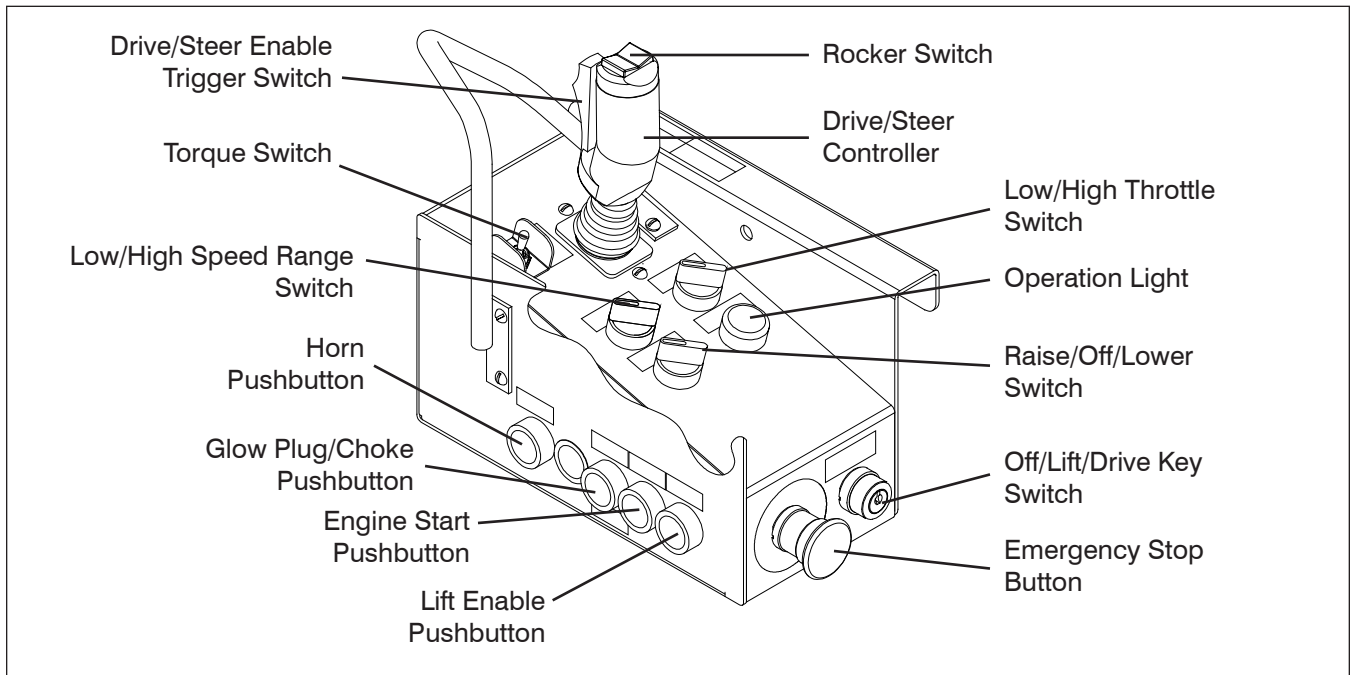

1. Ensure path of intended motion is clear.
2. Activate and hold “” enable trigger switch.
3. Slowly move controller fully “” forward, and then return handle to center position.
Result: Aerial platform should move in forward direction, and then come to a stop.
4. Slowly move controller fully “” backward, and then return handle to center position.
Result: Aerial platform should move in reverse direction, and then come to a stop.



- **Test Brake**





Brake will engage instantly when controller handle is released, causing aerial platform to stop immediately.

1. Ensure path of intended motion is clear.
2. Activate and hold “” enable trigger switch.
3. Drive aerial platform “” forward. Test brake by releasing controller handle.
Result: Aerial platform should come to a stop.
4. Drive aerial platform “” forward. Test brake again by releasing “” enable trigger switch only.
Result: Aerial platform should come to an instant and abrupt stop.

- **Test Elevated Drive Speed**



Be aware of overhead obstructions or other possible hazards around the aerial platform when lifting.

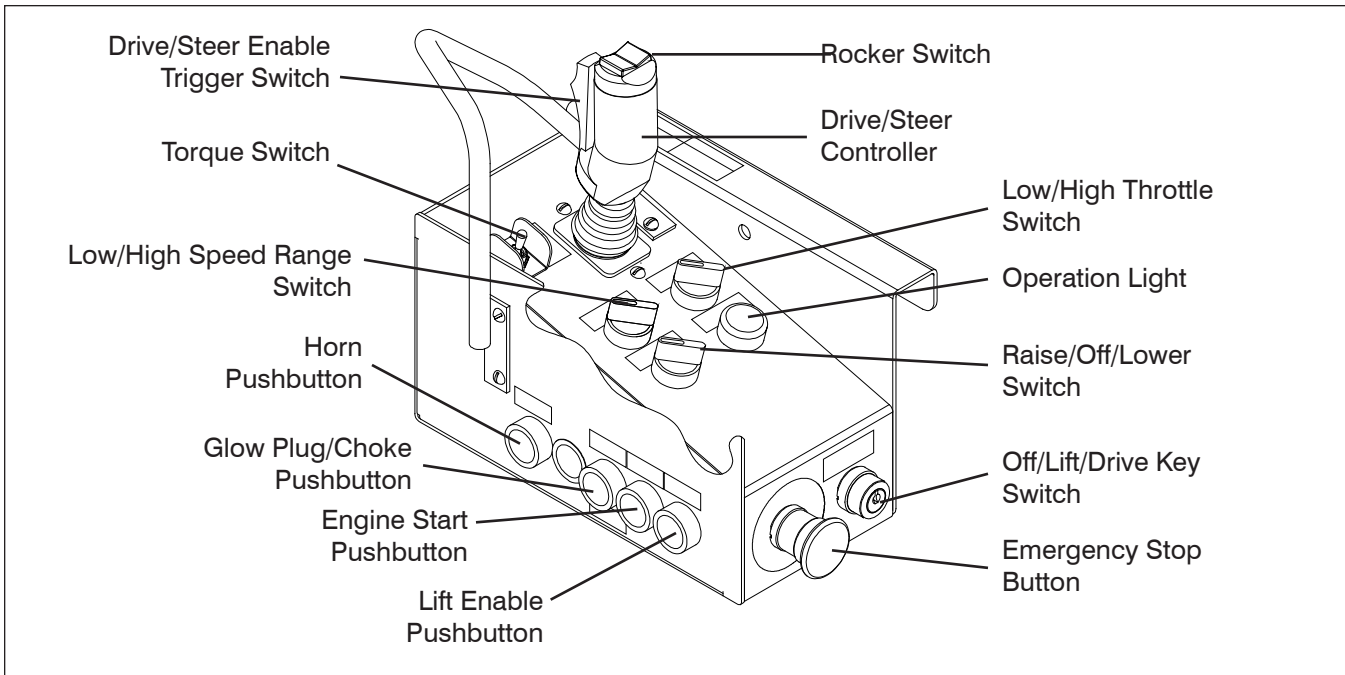

1. Ensure path of intended motion is clear.
2. Select off/lift/drive key switch to “” lift position.
3. Raise the platform to an approximate height of 4 meters.
4. Select off/lift/drive key switch to “” drive position and attempt to drive forward or reverse.
Result: Aerial platform should move slower than when it was in stowed position.
5. Fully lower the platform.



• **Test Lowering Warning**

1. Select off/lift/drive key switch to “ lift position.
2. Fully lower the platform.
Result: Platform should stop lowering at an approximate height of 2.5 meters and an alarm should sound.
3. Release platform raise/off/lower switch, ensure area around scissor is clear, then continue lowering the platform.
4. Lower the platform fully.

• **Test Powerdeck Enable**

1. Select and hold extend/retract switch to the “” extend position without selecting “” enable switch.
Result: Platform should not extend.

• **Test Extension Platform**

1. Extend each extension platform to about 0.5 meter.
Result: Each extension platform should extend.
2. Retract each extension platform fully.
Result: Each extension platform should fully retract.

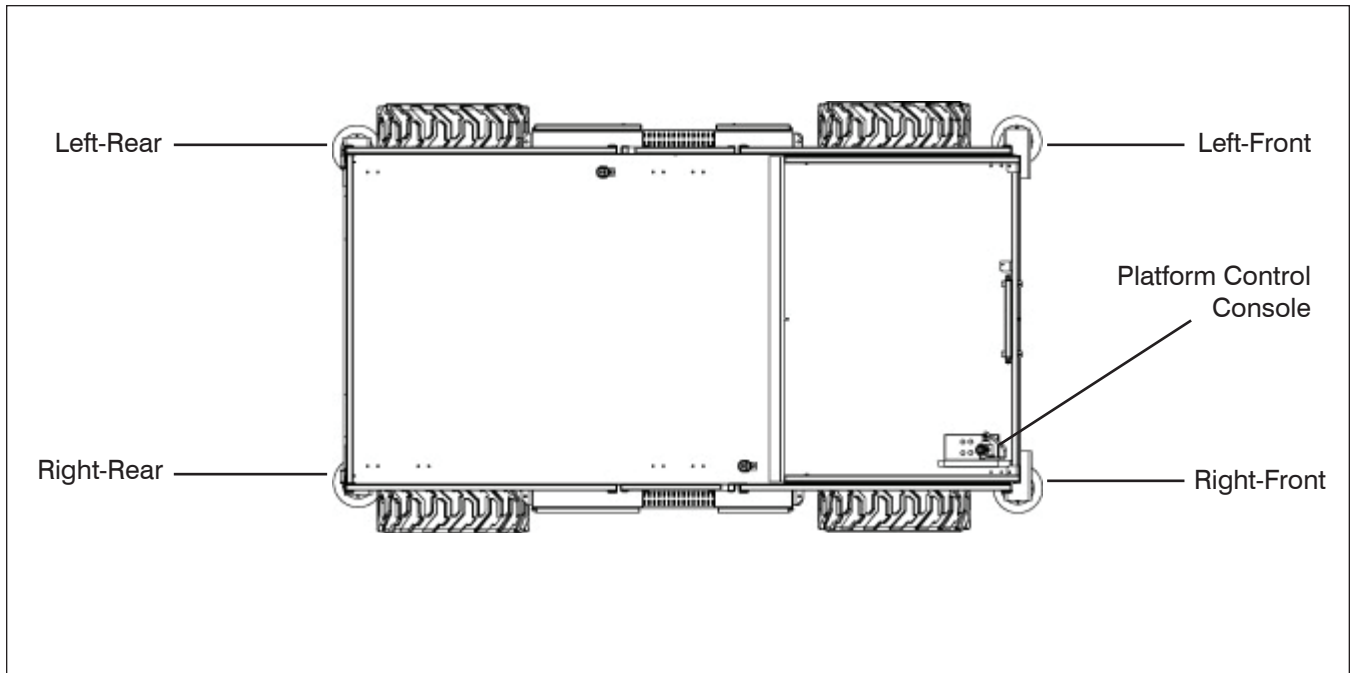

1.2-5 Test Hydraulic Outriggers

1. Ensure aerial platform is parked on a firm level surface and free from obstructions.
2. Ensure platform is fully lowered.
3. Ensure outriggers are fully retracted.
4. Auto-level (If equipped):
Use auto-level to extend outriggers.
Result: All four outriggers will extend until they are supporting weight and bring machine to within level.
5. Once auto-level is complete, attempt to lift platform 1 foot and then lower the platform to stowed position.
Result: Platform will lift and lower.
6. With platform at stowed position, fully retract all outriggers using auto-level.
Result: All four outriggers will retract until they are in the stowed (up) position.
7. Drive the aerial platform to maximum speed.
Result: Aerial platform drives at high speed.
8. Lift platform to 12 feet (measured from the bottom of the tires to the platform surface) from stowed position.
Result: Lift function will operate.
9. Drive aerial platform at raised height (12 feet).
Result: Aerial platform drives at slow speed.
10. Attempt to operate outriggers at raised height (12 feet).
 - Attempt to partially extend Left-Front Outrigger (approximately 4").
Result: Outrigger will not extend.
 - Attempt to partially extend Right-Front Outrigger (approximately 4").
Result: Outrigger will not extend.
 - Attempt to partially extend Right-Rear Outrigger (approximately 4").
Result: Outrigger will not extend.
 - Attempt to partially extend Left-Rear Outrigger (approximately 4").
Result: Outrigger will not extend.



WARNING

Be aware of overhead obstructions or other possible hazards around the aerial platform when lifting or driving.



WARNING

Ensure that there are no personnel or obstructions in the path of travel, including blind spots.

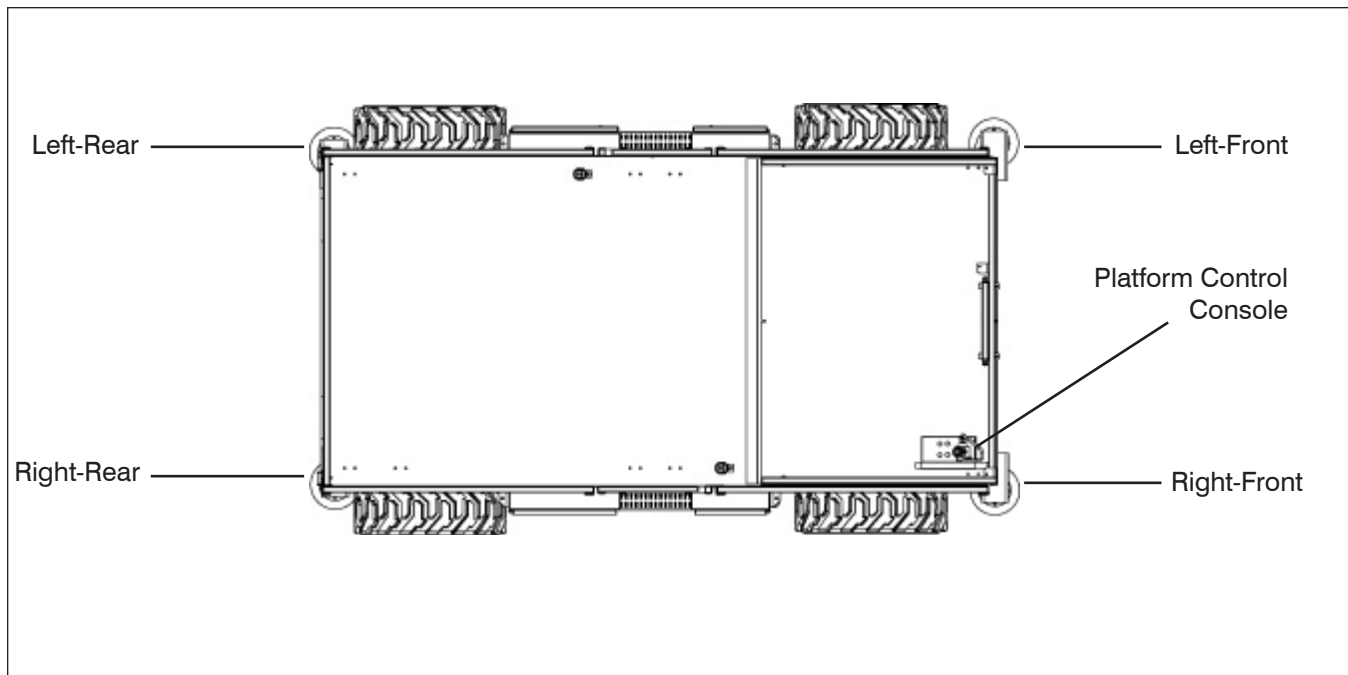

11. Lower the platform to stowed position.
Result: Lower function will operate.
12. Raise the platform 1 foot from stowed position and partially extend Left-Front Outrigger (approximately 4").
 - Attempt to lift the platform.
Result: Lift function will not operate.
 - Attempt to drive the aerial platform.
Result: Drive function will not operate.
 - Attempt to lower the platform.
Result: Lower function will operate.
13. Platform at stowed position.
 - With Left-Front Outrigger partially extended, attempt to lift the platform.
Result: Lift function will not operate.
 - With Right-Front Outrigger partially extended, attempt to lift the platform.
Result: Lift function will not operate.
 - With Right-Rear Outrigger partially extended, attempt to lift the platform.
Result: Lift function will not operate.
 - With Left-Rear Outrigger partially extended, attempt to lift the platform.
Result: Lift function will not operate.
14. Platform at stowed position.
 - Extend each outrigger until it raises the tires up approximately 2".
 - Retract the Left-Front Outrigger until the weight is resting on the corresponding tire.
 - Extend the Right-Rear Outrigger until it makes contact with ground.
 - Attempt to lift the platform 1 foot.
Result: Lift function will not operate.
15. Platform at stowed position.
 - Extend each outrigger until it raises the tires up approximately 2".
 - Retract the Right-Front Outrigger until the weight is resting on the corresponding tire.
 - Extend the Left-Rear Outrigger until it makes contact with ground.
 - Attempt to lift the platform 1 foot.
Result: Lift function will not operate.
16. Platform at stowed position.
 - Extend each outrigger until it raises the tires up approximately 2".
 - Retract the Right-Rear Outrigger until the weight is resting on the corresponding tire.

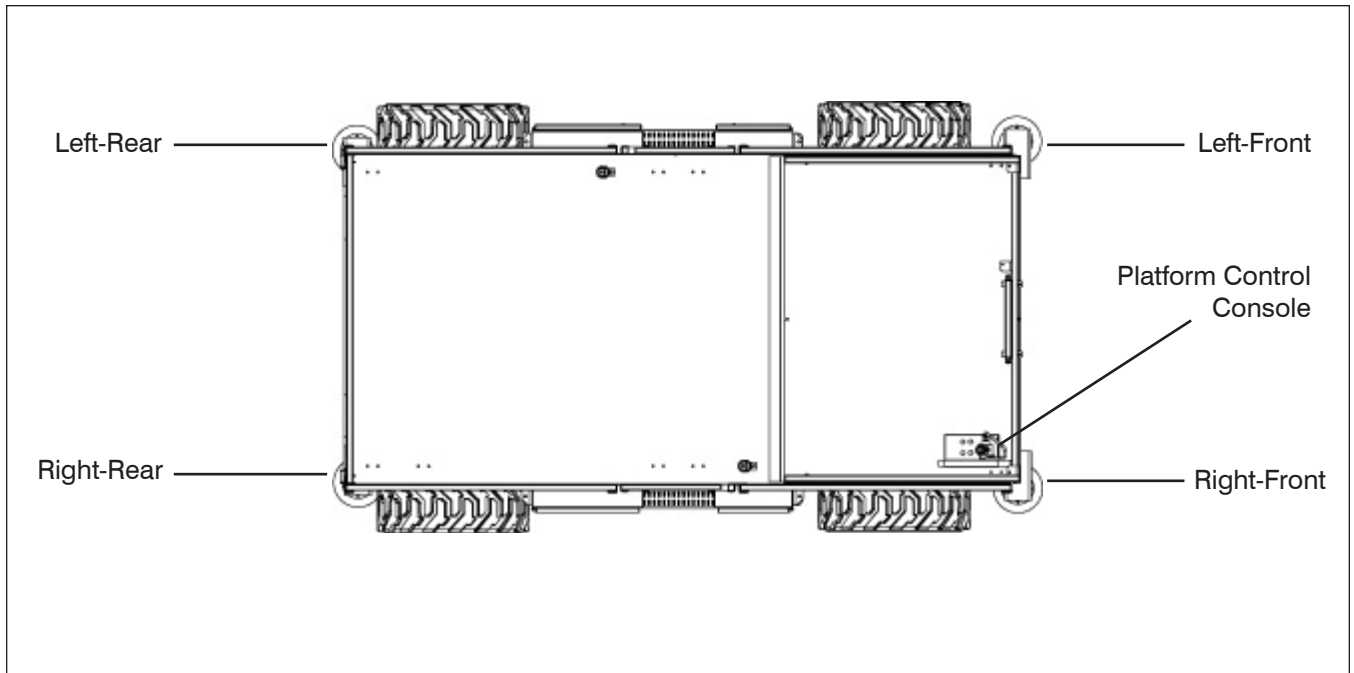

- Extend the Left-Front Outrigger until it makes contact with ground.
 - Attempt to lift the platform 1 foot.
Result: Lift function will not operate.
17. Platform at stowed position.
- Extend each outrigger until it raises the tires up approximately 2".
 - Retract the Left-Rear Outrigger until the weight is resting on the corresponding tire.
 - Extend the Right-Front Outrigger until it makes contact with ground.
 - Attempt to lift the platform 1 foot.
Result: Lift function will not operate.
18. Extend all four outriggers until all tires are off the ground and the aerial platform is levelled.
- Lift the platform to 12 feet.
Result: Lift function will operate.
 - Lower the platform from raised height (12 feet).
Result: Lower function will operate.



WARNING
If any outrigger interlocks fail to operate in the expected manner, the aerial platform should be tagged and removed from operation immediately.



WARNING
Repairs to the aerial platform may only be made by a qualified service technician.

Section 2 **MAINTENANCE TABLES AND DIAGRAMS**

Table of Contents

Tables

Table 2.1 Specifications and Features.....	42
Table 2.2 Maximum Platform Capacities (Evenly Distributed)	43
Table 2.3 Floor Loading Pressure.....	44
Table 2.4 Tire Specifications	46
Table 2.5 Rough Terrain Scissor Fluids	47
Table 2.6 Torque Specifications	49

Table 2.1 Specifications and Features

MODEL	Full-Size Rough Terrain	
	8841	9250
Weight *	6174 kg	7407 kg
Overall width	2.21 m	2.34 m
Overall length	3.7 m	4.55 m
Platform Size (inside)	1.7 m x 3.5 m	1.85 m x 4.39 m
Height		
Working Height	14.5 m	17.2 m
Platform Elevated Height	12.5 m	15.2 m
Stowed Platform Height	1.8 m	2 m
Drive Height	Full	7.9 m
Standard Operating Times		
Lift Time (Rated Load)	56 s	64 s
Lower Time (Rated Load)	53 s	86 s
Chassis		
Normal Drive Speed	4.2 km/h	3.8 km/h
Elevated Drive Speed	0.35 km/h	0.72 km/h
Gradeability (Ramp Angle)	30%	30%
Tires (Solid Rubber)	Refer to Table 4.6 for tire specification and usage.	
Hydraulic Oil		
Type	ATF Dexron III	
Tank Capacity (Liters)	75.71	67.38
Engine (RPM)		
Engine Type	Kubota D1305	
RPM Settings	1400 (Low) / 2800 (High)	
Fuel Type	Diesel	
Fuel Tank Capacity (Liters)	49.21	64.35
Engine Oil Type	SAE 10W-30	
Recommended Alternative Engine Oil	10W-30, API Service Designation CG-4, CF-4, CF, CD, SH	
Engine Oil Capacity (Liters)	6.0	
Coolant Type	Anti-freeze / Water	
Coolant Capacity (Liters)	4.0	

140AA-KC

* Weights are approximate; refer to serial nameplate for specific weight. Values shown for model 8841 are for standard 4WD aerial platforms on foam filled tires and two rollout extension platforms. Values shown for model 9250 are for standard 4WD on foam tires with two powered extension platforms.

Table 2.2 Maximum Platform Capacities (Evenly Distributed)

MODEL		Total		First Extension		Second Extension	
		Capacity	Number of Occupants	Capacity	Number of Occupants	Capacity	Number of Occupants
8841	Two Extension Platform	681 kg	5	227 kg	2	227 kg	2
9250	Two Extension Platform	681 kg	5	227 kg	2	227 kg	2

141AA-KC

NOTE:

Occupants and materials are not to exceed rated load.
 Capacities listed are for standard machines equipped with #6 tires.
 Refer to capacity label at sides of platform for additional information and for models equipped with options.

Note: Maximum Wind Speed = 12.5 m/sec

Table 2.3 Floor Loading Pressure

MODEL		Total Aerial Platform Weight	Total Aerial Platform Load		
			WHEEL	LCP **	OUP **
		kg	kg	kPa	kg/m ²
8841	min*	6174	2448	1312	795
	max*	7145	2858	1455	928
8841 Outrigger Pads	min*	6174	2566	496	759
	max*	7145	2858	553	846
9250	min*	7407	2963	1490	969
	max*	8137	3255	1576	975
9250 Outrigger Pads	min*	7407	2963	573	765
	max*	8137	3255	630	770

142AA-KC

- * **min** - Total aerial platform weight with no options
- * **max** - Aerial platform weight + all options + capacity
- ** **LCP - Locally Concentrated Pressure** is a measure of how hard the aerial platform presses on the areas in direct contact with the floor. The floor covering (tile, carpet, etc.) must be able to withstand more than the indicated values above.
- OUP - Overall Uniform Pressure** is a measure of the average load the aerial platform imparts on the whole surface directly underneath it. The structure of the operating surface (beams, etc.) must be able to withstand more than the indicated values above.

NOTE:

The **LCP** or **OUP** that an individual surface can withstand varies from structure to structure and is generally determined by the engineer or architect for that particular structure.

Floor Loading Pressure

Locally Concentrated Pressure (LCP):

Foot Print Area = Length x Width

or = $\frac{\pi D^2}{4}$ (for outriggers)

LCP = 0.4 x $\frac{\text{Weight of Aerial Platform} + \text{Capacity}}{\text{Foot Print Area}}$

Overall Uniform Pressure (OUP):

Base Area = Length x Width

OUP = $\frac{\text{Weight of Aerial Platform} + \text{Capacity}^*}{\text{Base Area}}$

* Capacity for max OUP only.

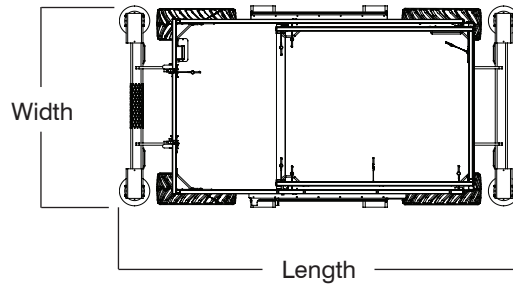
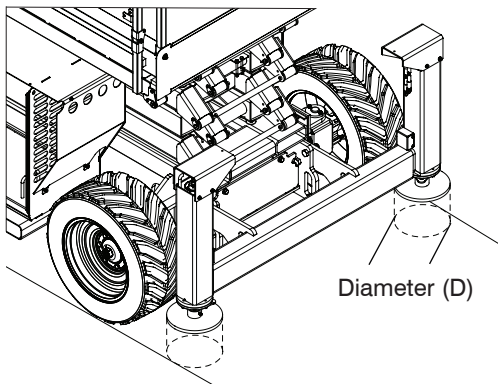
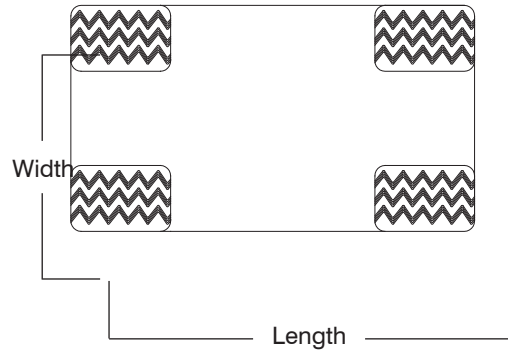
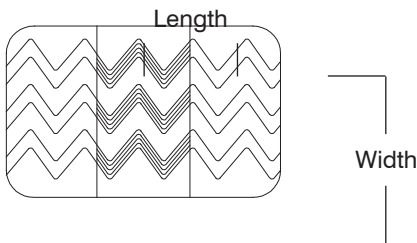
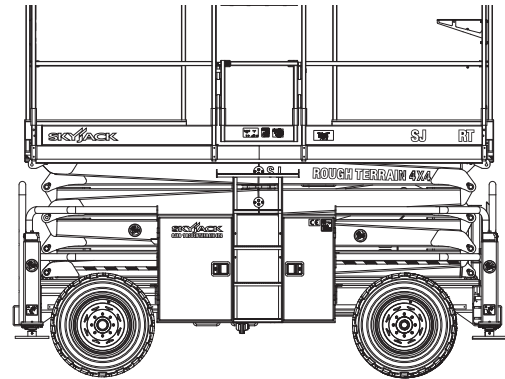
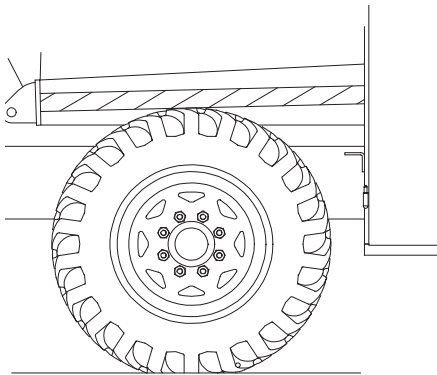

Table 2.4 Tire Specifications



Tires must be checked by end user on a daily basis. Do not intermix tires of different types on one aerial platform. Use only tires of type originally supplied.

Tire Size		Fill Specification			Usage*	
		Fill Type	Ply Rating	Pressure (Factory) (kPa)	Full-Size	
					8841	9250
#6F	10-16.5 CARLISLE US LOADER	Foam	10	N/A	S	S
#6F	10-16.5 OTR OUTRIGGER (Non-Marking)		10	N/A	O	O

143AA-KC

* Usage: (S)standard Or (O)ptional
(N/A) Not Available

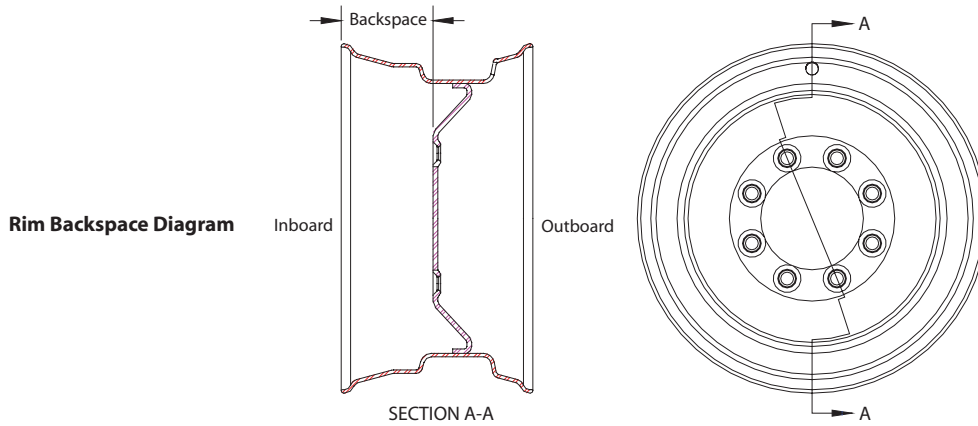

Rim Size	Backspace	
	8841	9250
#6F	121 mm	95 mm

144AA-KC



Intermixing tires of different types or using tires of types other than those originally supplied with this equipment can adversely affect stability. Therefore, replace tires only with the exact original Skyjack-approved type. Failure to operate with matched approved tires in good condition may result in death or serious injury.

Table 2.5 Rough Terrain Scissor Fluids

AXLE OIL					
Axle Type		Capacity (Liters)	Capacity (US Gallons)	Oil Type	Recommended Equivalent Oil
Cushman	Front	2.4	0.634	Gear Oil, 80W-90 GL5	-
Dana	Front / Rear				
Cushman	Rear	1	0.264	Gear Oil, ESI 80W-90	Chevron Gear Lubricant Delo ESI 80W-90, Caltex Gear Lubricant ESI 80W-90, Caltex RPM Borate EP 80W-90, Texaco Star Gear Lubricant 80W-90

CENTER DRIVE OIL				
Center Drive Type	Capacity (Liters)	Capacity (US Gallons)	Oil Type	Recommended Equivalent Oil
Center Drive	1	0.26	Gear Oil, 80W-90 GL5	-

HYDRAULIC OIL			
Model	Capacity (Liters)	Capacity (US Gallons)	Oil Type
SJ7127	80.48	21.26	ATF Dexron III
SJ7135			
SJ8831	75.71	20	
SJ8841			
SJ8831E			
SJ8841E			
SJ9241	67.38	17.8	
SJ9250			

Table 2.5 Rough Terrain Scissor Fluids (Continued)

ENGINE OIL				
Engine Type	Capacity (Liters)	Capacity (US Gallons)	Oil Type, Viscosity	Recommended Equivalent Oil (Viscosity - API Service Designation)
Kubota D902	3.9	1.03	Engine Oil, SAE 10W-30	10W30 - API Service Designation CG-4, CF-4, CF, CD, SH.
Kubota D1305	6.0	1.59		
Kubota D1105	5.1	1.35		
Kubota DF972	3.4	0.9		
Nissan A15	3.5	0.98		
GM 1.6				
				10W30 - API Service Designation SF/CC.

ENGINE COOLANT			
Component Type	Capacity (Liters)	Capacity (US Gallons)	*Coolant Type
Kubota D1305	4.0	1.06	Anti-freeze / Water
Kubota D902	3.1	0.82	
Kubota D1105			
Kubota DF972			
Nissan A15	11.4	3.01	Extended life anti-freeze / Water
GM 1.6			

* Use distilled water and 50/50 mix of anti-freeze/water.

Table 2.6 Torque Specifications

AB

CARTRIDGE									
Torque	Size								
	8	38	58	10	12	16			
Lb-ft (max)	20			25	35	50			
Lb-in (max)	240			300	420	600			
Nm (max)	27.12			33.9	47.46	67.8			
COILS									
Torque	Size								
	All coils								
Lb-ftt (max)	4 to 5								
Lb-in (max)	48 to 60								
Nm (max)	5.42 to 6.78								
SAE PLUGS									
Torque	Size								
	2	4	5	6	8	10	12	16	
Lb-ft (max)	3	10	15		25	30	35		
Lb-in (max)	36	120	180		300	360	420		
Nm (max)	4.07	13.56	20.34		33.9	40.68	47.46		
BOLTS									
Type of Bolt			Torque (ft-lb)			Torque (Nm)			
Directional valve mounting bolts			2.33 (28-32 in-lb)			3.16 - 3.61			
Wheel mounting bolts			140			189.8			
Center drive sprocket mounting bolts			110 - 115 (242 Loctite)			149 -156			
Hydraulic drive motor mounting bolts			120 (242 Loctite)			162			
Positive battery post cable/fuse nut			7.5 (90 in-lb)			10.2			
Newton-meter = Nm			Foot-Pound Force = ft-lb			Inch-Pound Force = in-lb			

60022AG_RT

Section 3

SYSTEM COMPONENT IDENTIFICATION AND SCHEMATICS

Table of Contents

Charts

3.1 Hydraulic Symbol Chart.....	52
3.2 Electrical Symbol Chart	53





















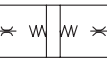

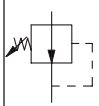



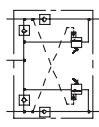







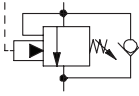

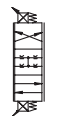

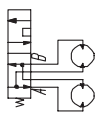

Parts List

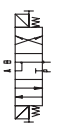
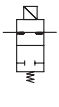
3.3 Hydraulic Component Parts List.....	54
3.4 Electrical Component Parts List	57

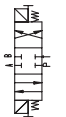
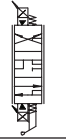
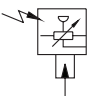



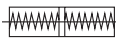





































Diagrams and Schematics

3.5 Platform Control Console Wiring - All Options (KC).....	62
3.6 Control Cable Assemblies Diagram	63
3.7 Outrigger & Hydraulic Generator Control Console Wiring.....	64
3.8 Base Control Console Wiring Diagram	65
3.9a Hydraulic Schematic.....	67
3.9b Hydraulic Schematic.....	68
3.10 Hydraulic Manifold Components & Port Identifications	69
3.11 Main Manifold Wiring Diagram	70
3.12 Emergency Lowering System - Wiring Diagram (Model 9250).....	71
3.13 Auto-Leveling Outrigger Wiring Diagram	72
3.14 Powered Extension Platform - Electrical Wiring Diagram (Model 9250).....	73
3.15 Horn, Light, Beeper & Transducer Wiring Diagram.....	74
3.16 Electrical Panel Diagram (KC)	75
3.17 Electrical Schematic - KC (All Option with Kubota Diesel Engine)	76

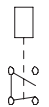
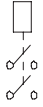
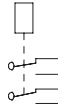
3.1 Hydraulic Symbol Chart

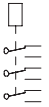
 LINE CROSSING	 VARIABLE DISPLACEMENT PUMP	 SHUTTLE VALV	 VELOCITY FUSE
 LINE JOINED	 HAND PUMP	 ACCUMULATOR, GAS CHARGED	 SINGLE ACTING CYLINDER
 HYDRAULIC TANK	 RELIEF VALVE	 CUSHION CYLINDER	 DOUBLE ACTING CYLINDER
 HYDRAULIC FILTER WITH BYPASS	 PRESSURE REDUCING VALVE	 PRESSURE SWITCH	 DOUBLE ACTING DOUBLE RODDED
 ELECTRIC MOTOR	 FIXED ORIFICE	 MOTION CONTROL VALVE	 SPRING APPLIED HYDRAULIC RELEASED BRAKE
 ENGINE	 ADJUSTABLE FLOW CONTROL	 FLOW DIVIDER COMBINER	 BRAKE CYLINDER
 FIXED DISPLACEMENT PUMP	 CHECK VALVE	 COUNTER BALANCE VALVE	 ROTARY ACTUATOR
 THREE POSITION FOUR WAY PROPORTIONAL	 OIL COOLER	 VALVE COIL	 BI DIRECTIONAL HYDRAULIC MOTOR
 SERIES PARALLEL HYDRAULIC MOTOR	 TWO POSITION TWO WAY NORMALLY CLOSED	 TWO POSITION THREE WAY	 THREE POSITION FOUR WAY CLOSED CENTER OPEN PORT
 TWO POSITION TWO WAY NORMALLY OPEN	 TWO POSITION THREE WAY	 THREE POSITION FOUR WAY CLOSED CENTER CLOSED PORT	 THREE POSITION FOUR WAY PROPORTIONAL
 PRESSURE TRANSDUCER	 MAIN LINES Solid	 PILOT LINES Dashed	 VARIABLE DISPLACEMENT HYDRAULIC MOTOR
 SERVO	 QUICK DISCONNECT		

3.2 Electrical Symbol Chart

	WIRE CROSSING		HOURMETER		KEY SWITCH		ANGLE TRANSDUCER
	WIRES JOINED		LIGHT		FOOT SWITCH		PRESSURE TRANSDUCER
	BATTERY		HYDRAULIC VALVE COIL		TOGGLE SWITCH		LIMIT SWITCH N.O.
	GROUND		PROPORTIONAL HYDRAULIC VALVE COIL		PUSH BUTTON		LIMIT SWITCH N.O. HELD CLOSED
	FUSE		ELECTRIC MOTOR		ROTARY SWITCH		LIMIT SWITCH N.C.
	CIRCUIT BREAKER		HORN		LIMIT SWITCH		LIMIT SWITCH N.C. HELD OPEN
	BATTERY CHARGE INDICATOR		EMERGENCY STOP BUTTON		CAM OPERATED LIMIT SWITCH		SILICON CONTROLLED RECTIFIER
	CAPACITOR		RESISTOR		TILT SWITCH		PROXIMITY SWITCH
	POTENTIOMETER		LEVEL SENSOR		SINGLE POLE SINGLE THROW RELAY		PNP TRANSISTOR
	SINGLE POLE DOUBLE THROW RELAY		DOUBLE POLE SINGLE THROW RELAY		DOUBLE POLE DOUBLE THROW RELAY		NPN TRANSISTOR
	TRIPLE POLE DOUBLE THROW RELAY		DIODE		TRANSISTOR		PRESSURE/ VACUUM SWITCH
	TEMPERATURE SWITCH						

3.3 Hydraulic Component Parts List

Index No.	Skyjack Part No.	Qty.	Description
2H-13A	103655	1	VALVE, Control (Lowering)
2H-13A-1	103655	1	VALVE, Control (Holding)
2H-13A-2	103655	1	VALVE, Control (Holding)
2H-13A-3	103655	1	VALVE, Control (Holding)
2H-13A-4	103655	1	VALVE, Control (Holding)
2H-14B	103655	1	VALVE, Control (Lift)
2H-17A	114365	1	VALVE, Control (Large pump dump)
2H-17B	103655	1	VALVE, Control (Outrigger holding)
2H-18A	103656	1	VALVE, Control (Small pump dump)
2H-25	102626	1	VALVE, Control (Quick brake)
2H-30A	112218	1	VALVE, Control (Free-wheeling)
2H-30A-1	103656	1	VALVE, Control (Brake dump)
2H-30A-2	103655	1	VALVE, Control (Brake feed)
2H-98-1	103655	1	VALVE, Control (Auxiliary lowering)
2H-98-2	103655	1	VALVE, Control (Auxiliary lowering)
2H-98-3	103655	1	VALVE, Control (Auxiliary lowering)
2H-98-4	103655	1	VALVE, Control (Auxiliary lowering)
3H-20A	103623	1	VALVE, Control (Series/Parallel)
4H-15B	139256	1	VALVE, Control (Reverse drive) (includes 4H-16B)
4H-16B	-	1	VALVE, Control (Forward drive)
4H-23A	153336	1	VALVE, Control (Right steer) (includes 4H-24A)
4H-24A	-	1	VALVE, Control (Left steer)
4H-26	153336	1	VALVE, Control (Front powered extension platform extend) (includes 4H-27)
4H-27	-	1	VALVE, Control (Front powered extension platform retract)
4H-26A	153336	1	VALVE, Control (Rear powered extension platform extend) (includes 4H-27A)
4H-27A	-	1	VALVE, Control (Rear powered extension platform retract)
4H-71	153336	1	VALVE, Control (Left front outrigger retract) (includes 4H-75)
4H-72	153336	1	VALVE, Control (Right front outrigger retract) (includes 4H-76)
4H-73	153336	1	VALVE, Control (Right rear outrigger retract) (includes 4H-77)
4H-74	153336	1	VALVE, Control (Left rear outrigger retract) (includes 4H-78)
4H-75	-	1	VALVE, Control (Left front outrigger extend)
4H-76	-	1	VALVE, Control (Right front outrigger extend)
4H-77	-	1	VALVE, Control (Right rear outrigger extend)
4H-78	-	1	VALVE, Control (Left rear outrigger extend)
BP1	133441	1	BRAKE PACK
C1	120353	1	CYLINDER (Lift)
C2	120353	1	CYLINDER (Lift)
C3	120353	1	CYLINDER (Lift)
C4	120353	1	CYLINDER (Lift)
C5	120422	1	CYLINDER (Brake)
C6	120422	1	CYLINDER (Brake)
C7	133474	1	CYLINDER (Steer)
C8	107752	1	CYLINDER (Cushion)
C9	132694	1	CYLINDER (Left front outrigger)
C10	132694	1	CYLINDER (Right front outrigger)
C11	132694	1	CYLINDER (Right rear outrigger)
C12	132694	1	CYLINDER (Left rear outrigger)
C13	120255	1	CYLINDER (Front powered platform)
C14	120255	1	CYLINDER (Rear powered platform)

3.3 Hydraulic Component Parts List (Continued)

AB

Index No.	Skyjack Part No.	Qty.	Description
CBV1	132249	1	VALVE, Counterbalance (Motion control) (for serial number 50000874 and below)
CBV1	158530	1	VALVE, Counterbalance (Motion control) (for serial number 50000875 and above)
CBV2	132249	1	VALVE, Counterbalance (Motion control) (for serial number 50000874 and below)
CBV2	158530	1	VALVE, Counterbalance (Motion control) (for serial number 50000875 and above)
CV1	104624	1	VALVE, Check (Small pump)
CV2	104624	1	VALVE, Check (Large pump)
CV3	104624	1	VALVE, Check (Lift)
CV4	104415	1	VALVE, Check (Left front outrigger)
CV5	104415	1	VALVE, Check (Right front outrigger)
CV6	104415	1	VALVE, Check (Right rear outrigger)
CV7	104415	1	VALVE, Check (Left rear outrigger)
CV11	132248	1	VALVE, Check (Motion control) (for serial number 50000874 and below)
CV11	158531	1	VALVE, Check (Motion control) (for serial number 50000875 and above)
CV12	132248	1	VALVE, Check (Motion control) (for serial number 50000874 and below)
CV12	158531	1	VALVE, Check (Motion control) (for serial number 50000875 and above)
CV13	132248	1	VALVE, Check (Motion control)
CV14	132248	1	VALVE, Check (Motion control)
DCMI	300248		DC MOTOR, 12V
F1	109568	1	RETURN FILTER ASSEMBLY
	104254	1	• ELEMENT, Filter
HP2	110652	1	HAND PUMP, Brake release
M1	109311	1	MOTOR, Center drive hydraulic
MB1	114178	1	BLOCK, Manifold (Main)
MB2	103137	1	BLOCK, Manifold (Emergency lowering)
MB3	118345	1	BLOCK, Manifold (Holding valve)
MB4	118345	1	BLOCK, Manifold (Holding valve)
MB5	118345	1	BLOCK, Manifold (Holding valve)
MB6	118345	1	BLOCK, Manifold (Holding valve)
MB7	125430	1	BLOCK, Manifold (Lift line)
MB8	125430	1	BLOCK, Manifold (Lift line)
MB9	113494	1	BLOCK, Manifold (Controlled lowering)
MB10	111943	1	BLOCK, Manifold (Disc brake)
MB11	111970	1	BLOCK, Manifold (Outrigger)
MB12	103137	1	BLOCK, Manifold (Hydraulic generator option)
MB13	111291	1	BLOCK, Manifold (Front powered platform)
MB14	111291	1	BLOCK, Manifold (Rear powered platform)
MB15	103615	1	BLOCK, Manifold (Free-wheeling valve)
MB16	132261	1	BLOCK, Manifold (Motion control) (for serial number 50000874 and below)
MB16	158529	1	BLOCK, Manifold (Motion control) (for serial number 50000875 and above)
MC1	132244	1	MOTION CONTROL ASSEMBLY
O1	131927	1	ORIFICE (0.096 diameter) (Main)

3.3 Hydraulic Component Parts List (Continued)

Index No.	Skyjack Part No.	Qty.	Description
O2	105501	4	ORIFICE (0.094 diameter) (Lift cylinder)
O5	108721	1	ORIFICE (0.055 diameter) (Controlled lowering)
P1	110460	1	PUMP, Hydraulic dual (0.488/0.854)
P3	113173	1	PUMP, Power platform
PS1	102863	1	PRESSURE SWITCH (option) (trips at 2400 psi)
PT1	134432	1	TRANSDUCER, Pressure
QD1	122419	1	QUICK DISCONNECT (System pressure)
R1	104534	1	VALVE, Relief (System)
R2	104534	1	VALVE, Relief (Lift)
R3	104534	1	VALVE, Relief (Cylinder)
R4	104534	1	VALVE, Relief (Cylinder)
R5	104534	1	VALVE, Relief (Cylinder)
R6	104534	1	VALVE, Relief (Cylinder)
R8	113286	1	VALVE, Relief (Set at 500psi) (Powered platform)
V1	107271	1	VALVE, Emergency lowering
V2	113556	1	VALVE, Controlled lowering
V6	113752	1	VALVE, Brake release (Auto reset)

3.4 Electrical Component Parts List

RELAY DIAGRAM

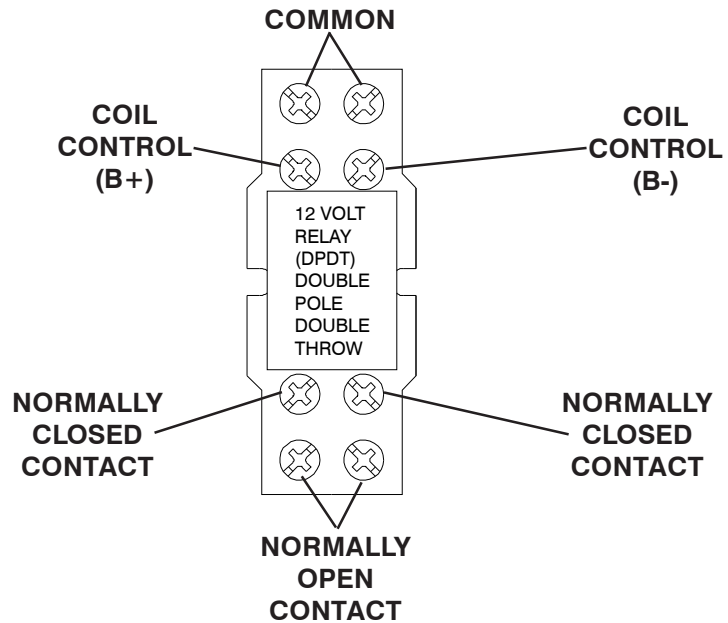
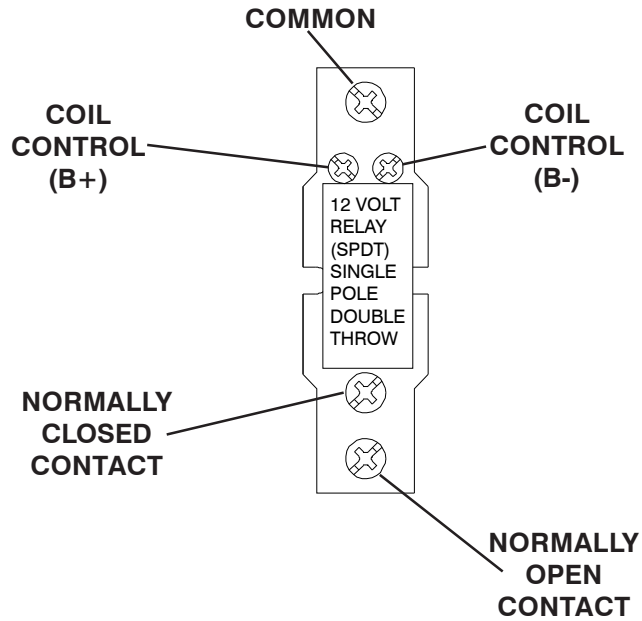

3.4 Electrical Component Parts List

Index No.	Skyjack Part No.	Qty.	Description
1TD	103207	1	RELAY, 12 Volt DPDT (Drive time delay)
2D37	147131	1	SOLENOID, Stop (Diesel engine)
9CR1	111787	1	CONTACTOR, 12 Volt (powered extension platform option)
9CR2	127131	1	RELAY, 12 Volt (Outrigger enable)
9CR3	127131	1	RELAY, 12 Volt (Outrigger enable proof)
10ACR1	103207	1	RELAY, 12 Volt DPDT (Engine protection relay)
10BCR1	103316	1	RELAY, 12 Volt SPDT (Engine on)
12BCR	127035	1	RELAY, Joystick Enable Switch
13CR	103316	1	RELAY, 12 Volt SPDT (Down)
14CR	103316	1	RELAY, 12 Volt SPDT (Up)
15CR	103316	1	RELAY, 12 Volt SPDT (Reverse drive)
16CR	103316	1	RELAY, 12 Volt SPDT (Forward drive)
17CR	103316	1	RELAY, 12 Volt SPDT (2nd speed/large pump)
17ACR	103316	1	RELAY, 12 Volt SPDT (Small pump)
17DCR	127131	1	RELAY, 12 Volt SPDT (Outrigger trigger)
18CR	103316	1	RELAY, 12 Volt SPDT (3rd speed)
20CR	103316	1	RELAY, 12 Volt SPDT (Series/Parallel drive)
23CR	103316	1	RELAY, 12 Volt SPDT (Right steer)
24CR	103316	1	RELAY, 12 Volt SPDT (Left steer)
28CR	103207	1	RELAY, 12 Volt DPDT (Tilt switch)
30CR	103316	1	RELAY, 12 Volt SPDT (Brake)
31CR	103316	1	RELAY, Choke/Glow Plug (SPDT)
31ACR	127035	1	RELAY, 12 Volt SPDT (Kubota diesel engine glow plug)
32CR	103207	1	RELAY, 12 Volt DPDT (Engine start)
32ACR	147125	1	SOLENOID (Kubota Diesel engine starter)
34BCR	103316	1	RELAY, 12 Volt SPDT (Throttle)
35CR	103207	1	RELAY, 12 Volt DPDT (Tilt override)
49CR	103316	1	RELAY, 12 Volt SPDT (Horn)
56CR	143805	1	RELAY, 12V (20A/35A) (GM fuel pump)
61CR	127131	1	RELAY, 12 Volt SPDT (Outrigger)
65CR	127131	1	RELAY, 12 Volt SPDT (Outrigger lift enable)
99CR	300242	1	SOLENOID, 12 Volt motor (Powered extension platform)
2002CR	143805	1	RELAY, 12 Volt (20A/35A) (Power unit)
2H-13A	103613	1	COIL, 12 Volt (Lowering valve)
2H-13A-1	104410	1	COIL, 12 Volt (Lift cylinder holding valve)
2H-13A-2	104410	1	COIL, 12 Volt (Lift cylinder holding valve)
2H-13A-3	104410	1	COIL, 12 Volt (Lift cylinder holding valve)
2H-13A-4	104410	1	COIL, 12 Volt (Lift cylinder holding valve)
2H-14B	103613	1	COIL, 12 Volt (Lift valve)
2H-17A	106272	1	COIL, 12 Volt (Large pump dump valve)
2H-17B	103613	1	COIL, 12 Volt (Outrigger holding valve)
2H-18A	103613	1	COIL, 12 Volt (Small pump dump valve)
2H-25	103613	1	COIL, 12 Volt (Brake valve)
2H-30A	103613	1	COIL, 12 Volt (Free-wheeling valve)
2H-30A-1	103613	1	COIL, 12 Volt (Brake dump valve)
2H-30A-2	103613	1	COIL, 12 Volt (Brake feed valve)
2H-86C	106272	1	COIL, 12 Volt (Hydraulic generator valve)
2H-98-1	104410	1	COIL, 12 Volt (Auxiliary holding valve)
2H-98-2	104410	1	COIL, 12 Volt (Auxiliary holding valve)
2H-98-3	104410	1	COIL, 12 Volt (Auxiliary holding valve)
2H-98-4	104410	1	COIL, 12 Volt (Auxiliary holding valve)

3.4 Electrical Component Parts List (Continued)

Index No.	Skyjack Part No.	Qty.	Description
3H-20A	103613	1	COIL, 12 Volt (Series/Parallel drive valve)
4H-15B	128321	1	COIL, 12 Volt (Reverse drive valve)
4H-16B	128321	1	COIL, 12 Volt (Forward drive valve)
4H-23A	153337	1	COIL, 12 Volt (Right steer valve)
4H-24A	153337	1	COIL, 12 Volt (Left steer valve)
4H-26	153337	1	COIL, 12 Volt (Front powered extension platform extend valve)
4H-27	153337	1	COIL, 12 Volt (Front powered extension platform retract valve)
4H-26A	153337	1	COIL, 12 Volt (Rear powered extension platform extend valve)
4H-27A	153337	1	COIL, 12 Volt (Rear powered extension platform retract valve)
4H-71	153337	1	COIL, 12 Volt (Left front outrigger retract)
4H-72	153337	1	COIL, 12 Volt (Right front outrigger retract)
4H-73	153337	1	COIL, 12 Volt (Right rear outrigger retract)
4H-74	153337	1	COIL, 12 Volt (Left rear outrigger retract)
4H-75	153337	1	COIL, 12 Volt (Left front outrigger extend)
4H-76	153337	1	COIL, 12 Volt (Right front outrigger extend)
4H-77	153337	1	COIL, 12 Volt (Right rear outrigger extend)
4H-78	153337	1	COIL, 12 Volt (Left rear outrigger extend)
B1	103295	1	BATTERY, 12 Volt
B2	108789	1	BATTERY, 12 Volt (Auxiliary)
BP-29	103056	1	BEEPER (7.5 - 16 VDC)
CAP1	103319	1	CAPACITOR, 50 Volt (1000MFD)
CB1	117326	1	BREAKER, Circuit (20 Amp)
CB3	117326	1	BREAKER, Circuit (20 Amp)
CRD1	115283	1	CABLE ASSEMBLY (Platform)
CRD2	115280	1	CABLE ASSEMBLY (Scissor)
CRD3	134417	1	CABLE ASSEMBLY (Electrical panel)
DA1	127688	1	DIODE ASSEMBLY (D28A)
DA2	129434	1	DIODE ASSEMBLY (D30A)
DA3	127684	1	DIODE ASSEMBLY (D44)
DA9	132807	1	DIODE ASSEMBLY (D17A, D18A)
DA10	129213	1	DIODE ASSEMBLY (D15A, D16A)
DA12	104313	1	DIODE ASSEMBLY (D15A-1, D16A-1, D23A, D24A)
D02-XX	700166	AR	DIODE, Small
DXX	102921	AR	DIODE, Common
DCM1	300248	1	MOTOR, 12 Volt (Powered extension platform)
EGP1	KUBOTA	1	PLUG, Engine glow (Diesel fuel Engine)
F2	111282	1	FUSE (100 Amp) (Powered extension platform)
F4	119469	1	FUSE (200 Amp) (Inverter Option)
F5	120658	1	FUSE (10 Amp) (Powered extension platform)
FL-22	126677	1	FLASHING LIGHT, 12 Volt
FL-29	103743	1	FLASHER
G	137138	1	ALTERNATOR (Diesel fuel engine)
GPL1	132884	1	LIGHT, Glow Plug Indicator (Diesel fuel engine)
GPT1	132883	1	TIMER, Glow Plug (Diesel fuel engine)
H1	146652	1	HORN, 12 Volt
HTS-34A	106370	1	SOLENOID, High throttle (Diesel fuel engine)
LED1	147229	1	POWER INDICATOR LIGHT (Platform control console)
LED2	147229	1	POWER INDICATOR LIGHT (Base control console)
LED3	147229	1	POWER INDICATOR LIGHT (Platform control console)
LS1	119375	1	LIMIT SWITCH (26 Feet lift cut-out)
LS4	115658	1	LIMIT SWITCH (End-of-stroke)

3.4 Electrical Component Parts List (Continued)

Index No.	Skyjack Part No.	Qty.	Description
LS5	119296	1	LIMIT SWITCH (Elevation/High speed cut-out)
LS61	115658	1	LIMIT SWITCH (Left front outrigger extend)
LS62	115658	1	LIMIT SWITCH (Right front outrigger extend)
LS63	115658	1	LIMIT SWITCH (Right rear outrigger extend)
LS64	115658	1	LIMIT SWITCH (Left rear outrigger extend)
LS65	115658	1	LIMIT SWITCH (Left front outrigger retract)
LS66	115658	1	LIMIT SWITCH (Right front outrigger retract)
LS67	115658	1	LIMIT SWITCH (Right rear outrigger retract)
LS68	115658	1	LIMIT SWITCH (Left rear outrigger retract)
M	147125	1	MOTOR, Engine starter (Diesel fuel engine)
OCM1	132804	1	MODULE, Auto-level control (Outrigger)
OL1	133133	1	LIGHT, Outrigger indicator
OPS1	102838	1	SWITCH, Oil pressure (Diesel fuel engine)
RL-29	107098	1	BEACON, Rotating Amber (Option)
RST2	108788	1	RESISTOR (3 Ohm/100W)
S1	119726	1	SWITCH, Main power disconnect
S2	147054	2	N.O. CONTACT (Base - up/off/down switch)
S3	147054	1	N.O. CONTACT (Platform - off/lift/drive select key switch)
	147053	2	N.C. CONTACT (Platform - off/lift/drive select key switch)
S4	147053	1	N.C. CONTACT (Platform - emergency stop switch)
S5	147054	2	N.O. CONTACT (Platform - up/down switch)
S6	147053	1	N.C. CONTACT (Base - emergency stop switch)
S7	132537	1	DRIVE/STEER CONTROLLER ASSEMBLY
S7-1	122869	1	• SWITCH (2nd speed)
S7-2	122877	1	• SWITCH (Right steer)
S7-3	122877	1	• SWITCH (Left steer)
S7-4	122869	1	• SWITCH (Reverse drive)
S7-5	122869	1	• SWITCH (Forward drive)
S7-6	122869	1	• SWITCH (3rd speed)
S7-7	122872	1	• SWITCH (Enable pushbutton)
S8	147054	1	N.O. CONTACT (Platform - Horn pushbutton)
S9	147054	1	N.O. CONTACT (Platform - Lift enable switch)
S9A	102853	1	SWITCH, Toggle (Outrigger enable)
S9B	127132	1	SWITCH, Toggle (Outrigger enable)
S10	147054	1	N.O. CONTACT (Base - enable switch)
S11	102853	1	SWITCH, Toggle (Front powered platform extend/retract)
S11A	102853	1	SWITCH, Toggle (Rear powered platform extend/retract)
S12	102853	1	SWITCH, Toggle (Hydraulic generator option)
S13	147054	1	N.O. CONTACT (Platform - choke/glow plug switch)
S14	147054	1	N.O. CONTACT (Platform - low/high throttle switch)
S15	147054	1	N.O. CONTACT (Platform - engine start switch)
S20	102853	1	SWITCH, Toggle (Platform - left front outrigger extend/retract)
S21	102853	1	SWITCH, Toggle (Platform - right front outrigger extend/retract)
S22	102853	1	SWITCH, Toggle (Platform - right rear outrigger extend/retract)
S23	102853	1	SWITCH, Toggle (Platform - left rear outrigger extend/retract)
S20A	127132	1	SWITCH, Toggle (Base - left front outrigger extend/retract)
S21A	127132	1	SWITCH, Toggle (Base - right front outrigger extend/retract)
S22A	127132	1	SWITCH, Toggle (Base - right rear outrigger extend/retract)
S23A	127132	1	SWITCH, Toggle (Base - left rear outrigger extend/retract)
S24	102853	1	SWITCH, Toggle (Platform - outrigger auto-level)

3.4 Electrical Component Parts List (Continued)

Index No.	Skyjack Part No.	Qty.	Description
S29	147054	1	N.O. CONTACT (Platform - low/high range)
S30	124446	1	SWITCH, Toggle (Engine panel - engine off/on)
S31	102853	1	SWITCH, Toggle (Kubota engine panel - glow plug)
S34	102853	1	SWITCH, Toggle (Front powered platform enable)
S34A	102853	1	SWITCH, Toggle (Rear powered platform enable)
S41	114373	1	SWITCH, Toggle (Platform - high/low torque)
S51	103141	1	N.O. CONTACT (Emergency lowering switch)
S52	103141	1	N.O. CONTACT (Emergency retraction switch)
TPS1	113400	1	TEMPERATURE SWITCH, Engine (Kubota diesel)
TT	103336	1	HOUR METER

3.5 Platform Control Console Wiring - All Options (KC)

CONTROL BOX HARNESS		PIN # - FUNCTION	JOYSTICK HARNESS	
24	BLUE/BLACK	PIN 1 - LEFT	24	WHITE/RED
12	BROWN/RED	PIN 2 - JOYSTICK VS+	12	WHITE/BLACK
23	BLACK/WHITE	PIN 3 - RIGHT	23	WHITE
16	WHITE/BLACK	PIN 4 - FORWARD	16	YELLOW
12A	BROWN/RED	PIN 5 - STEERING VS+	12A	WHITE/GREEN
15	BLUE	PIN 6 - REVERSE	15	GREY
19	ORANGE/BLACK	PIN 7 - 2nd SPEED	19	BROWN
12A	BROWN/RED	PIN 8 - ENABLE VS+	12A	WHITE/BLUE
18B	RED/BLACK	PIN 9 - 3rd SPEED	18B	RED/BLACK

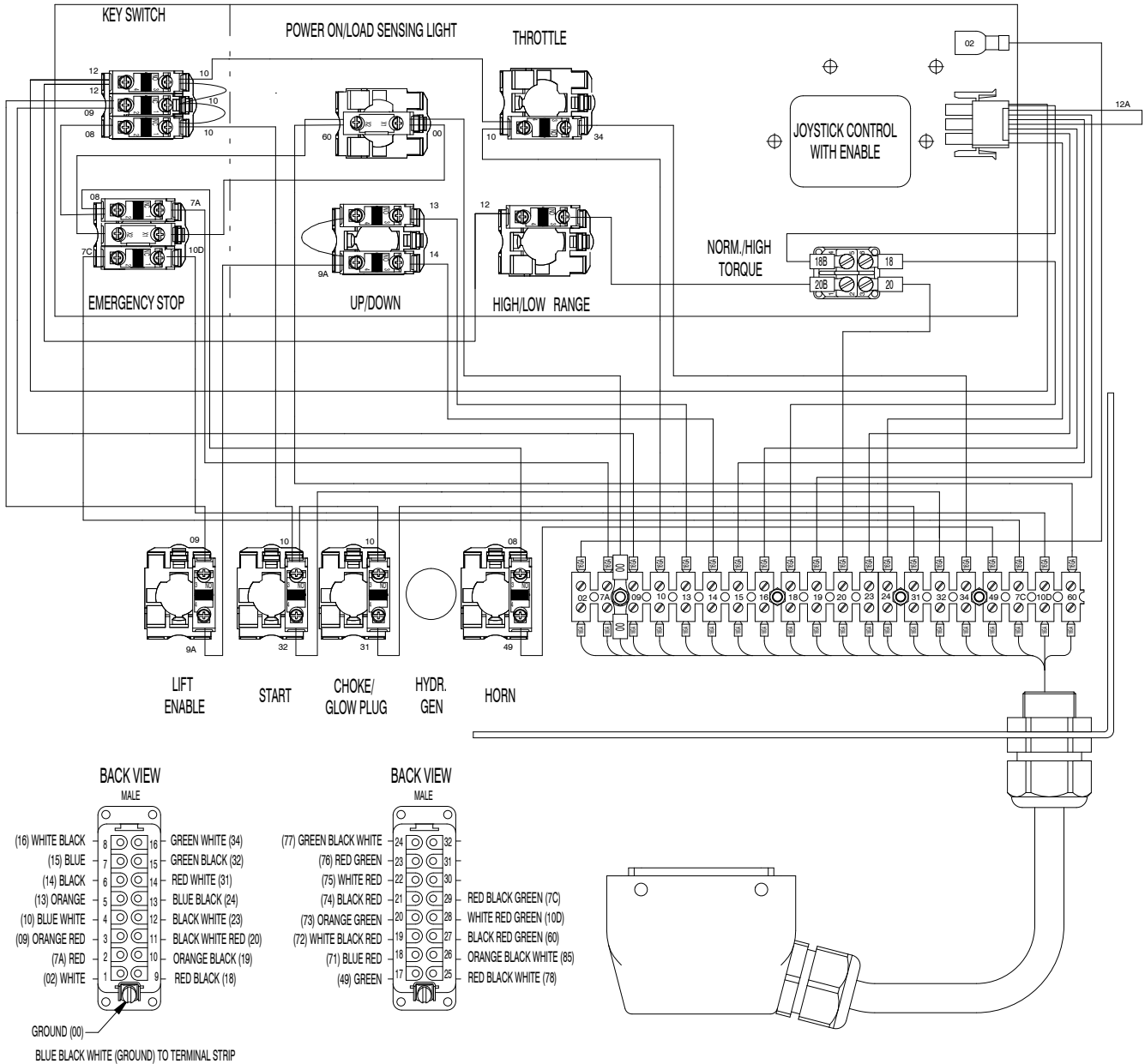

BACK VIEW
MALE

- (16) WHITE BLACK
- (15) BLUE
- (14) BLACK
- (13) ORANGE
- (10) BLUE WHITE
- (09) ORANGE RED
- (7A) RED
- (02) WHITE
- GROUND (00)
- BLUE BLACK WHITE (GROUND) TO TERMINAL STRIP

BACK VIEW
MALE

- (77) GREEN BLACK WHITE
- (76) RED GREEN
- (75) WHITE RED
- (74) BLACK RED
- (73) ORANGE GREEN
- (72) WHITE BLACK RED
- (71) BLUE RED
- (49) GREEN
- RED BLACK GREEN (7C)
- WHITE RED GREEN (10D)
- BLACK RED GREEN (60)
- ORANGE BLACK WHITE (65)
- RED BLACK WHITE (78)

M147223AE

3.6 Control Cable Assemblies Diagram

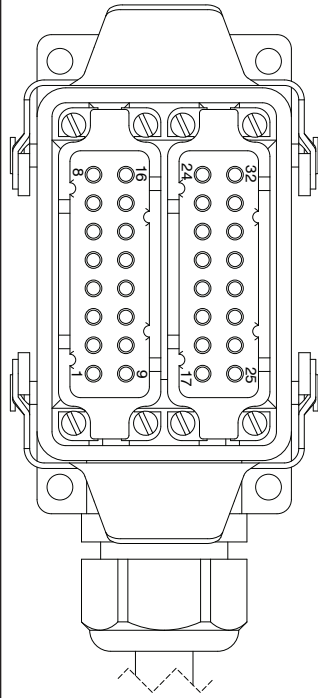

INSERTS 1-16

- PIN 1 - WHITE (02)
- PIN 2 - RED (7A)
- PIN 3 - ORANGE RED (09)
- PIN 4 - BLUE WHITE (10)
- PIN 5 - ORANGE (13)
- PIN 6 - BLACK (14)
- PIN 7 - BLUE (15)
- PIN 8 - WHITE BLACK (16)
- PIN 9 - RED BLACK (18)
- PIN 10 - ORANGE BLACK (19)
- PIN 11 - BLACK WHITE RED (20)
- PIN 12 - BLACK WHITE (23)
- PIN 13 - BLUE BLACK (24)
- PIN 14 - RED WHITE (31)
- PIN 15 - GREEN BLACK (32)
- PIN 16 - GREEN WHITE (34)
- GROUND TERMINAL - BLUE BLACK WHITE

INSERTS: 17-32

- PIN 17 - GREEN (49)
- PIN 18 - BLUE RED (71)
- PIN 19 - WHITE BLACK RED (72)
- PIN 20 - ORANGE GREEN (73)
- PIN 21 - BLACK RED (74)
- PIN 22 - WHITE RED (75)
- PIN 23 - RED GREEN (76)
- PIN 24 - GREEN BLACK WHITE (77)
- PIN 25 - RED BLACK WHITE (78)
- PIN 26 - ORANGE BLACK WHITE (85)
- PIN 27 - BLACK RED GREEN (60)
- PIN 28 - WHITE RED GREEN (10D)
- PIN 29 - RED BLACK GREEN (7C)
- PIN 30 - EMPTY
- PIN 31 - EMPTY
- PIN 32 - EMPTY
- GROUND TERMINAL - EMPTY

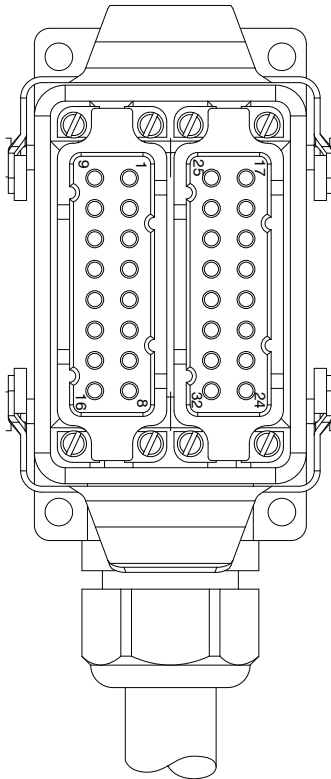
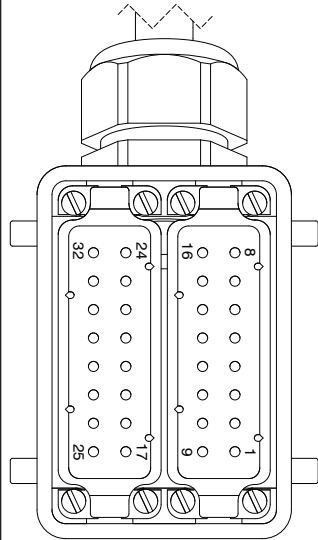

TO CONTROL BOX

TO CONTROL BOX

BACK VIEW

FEMALE

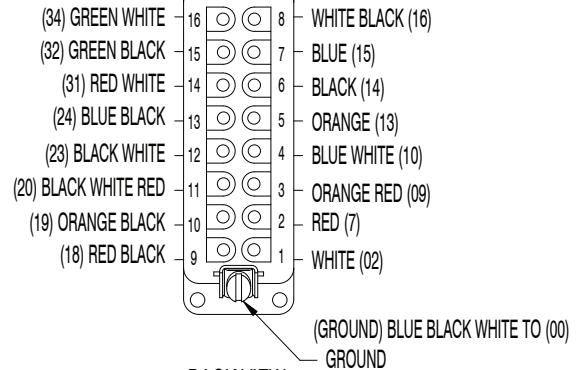

BACK VIEW

FEMALE

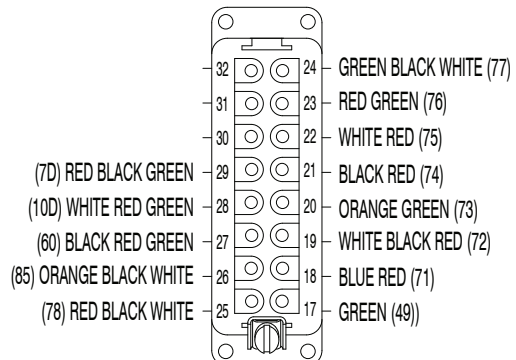

M115279AD_M115284AE

3.7 Outrigger & Hydraulic Generator Control Console Wiring

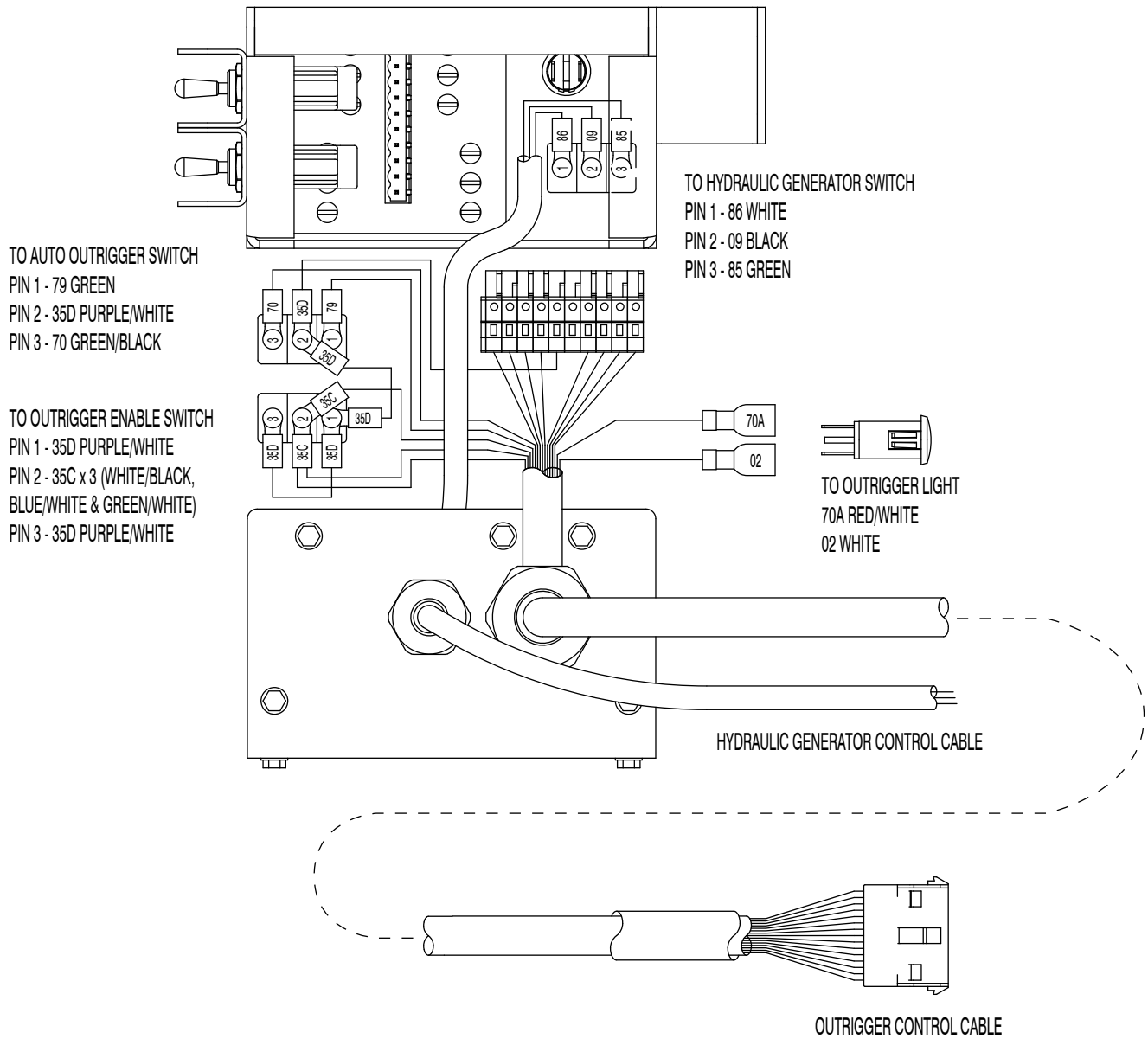

M129301AB

3.8 Base Control Console Wiring Diagram

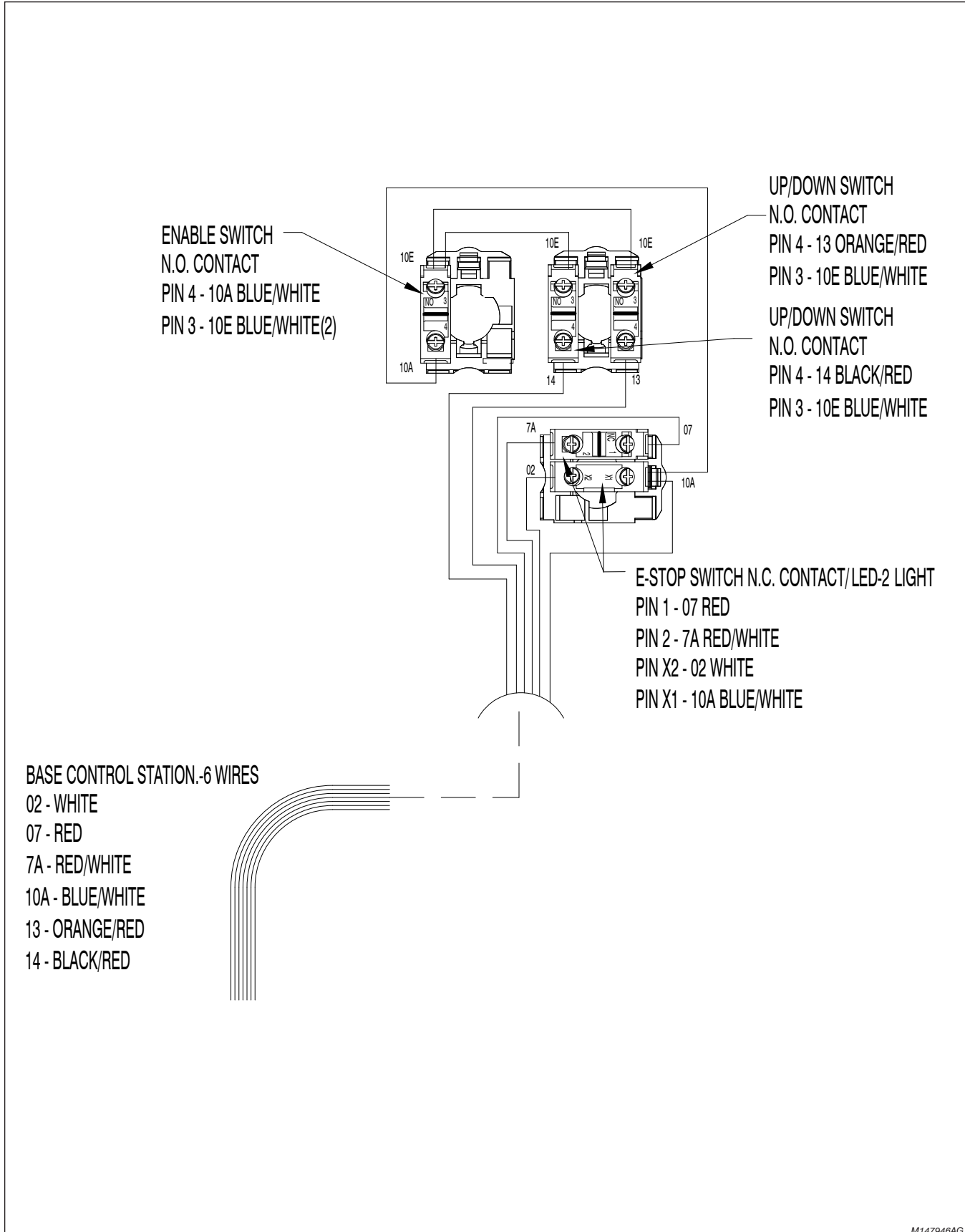

M147946AG

3.9a Hydraulic Schematic

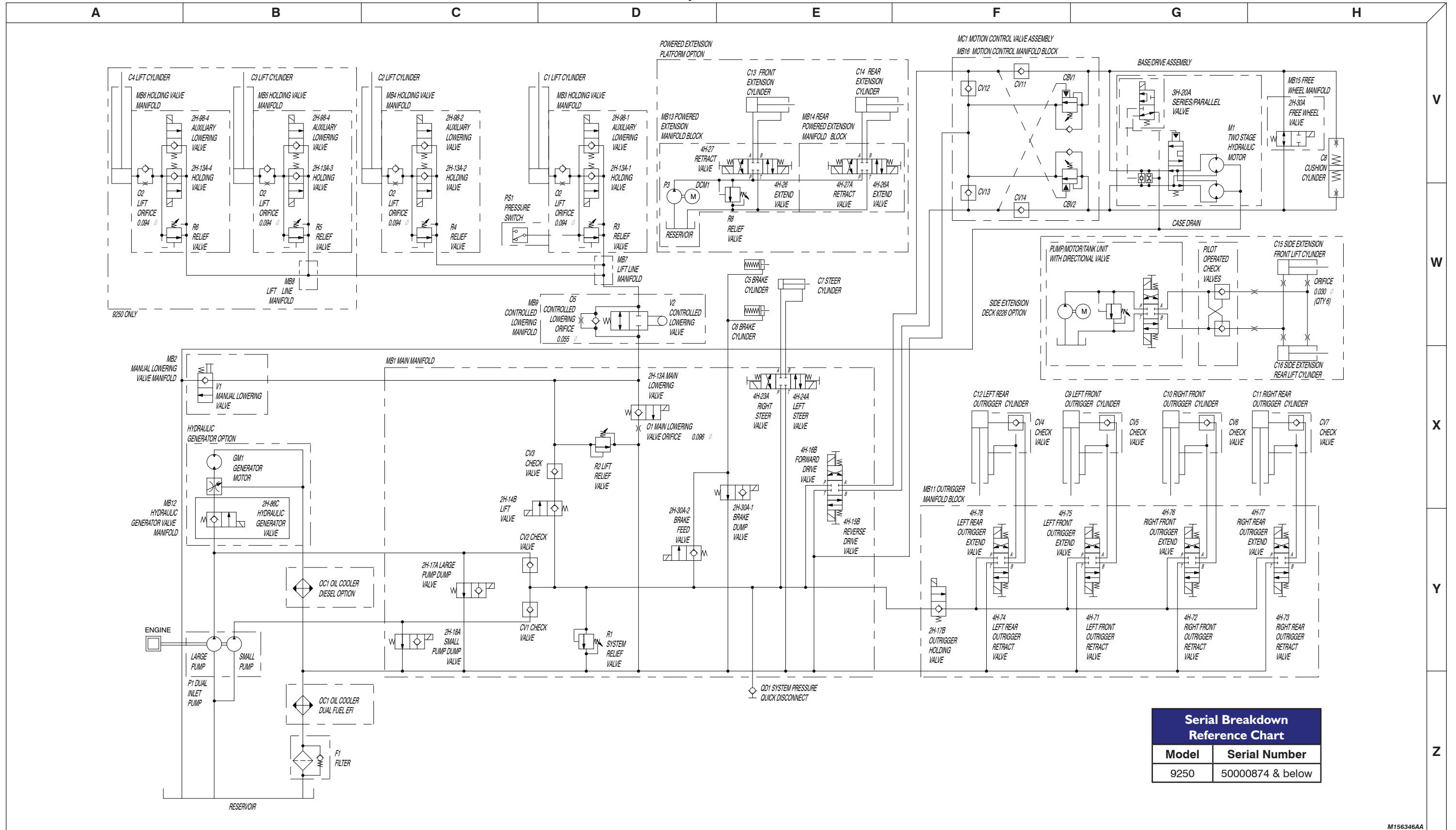

Serial Breakdown Reference Chart	
Model	Serial Number
9250	50000874 & below

3.9b Hydraulic Schematic

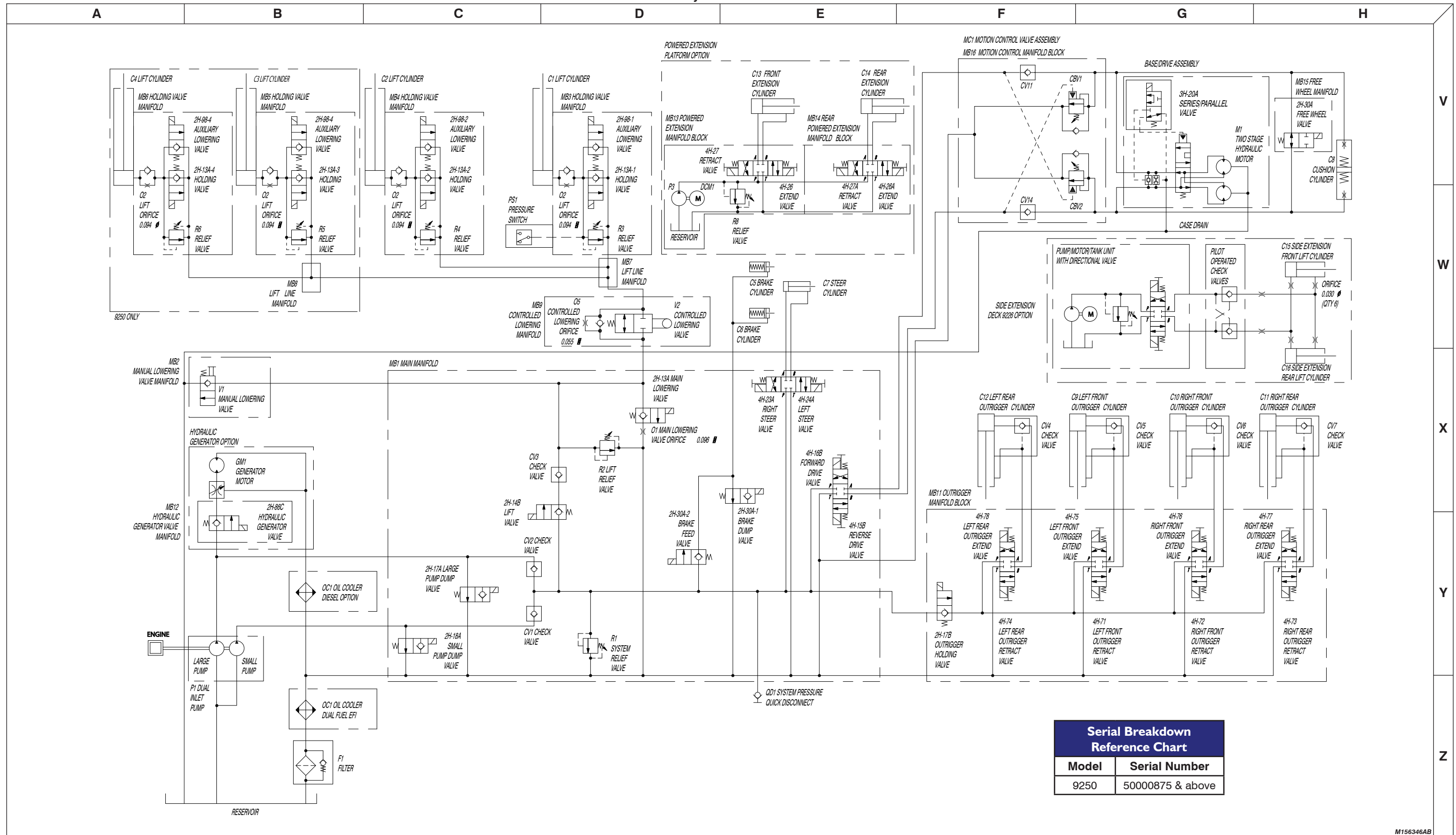

Serial Breakdown Reference Chart	
Model	Serial Number
9250	50000875 & above

3.10 Hydraulic Manifold Components & Port Identifications

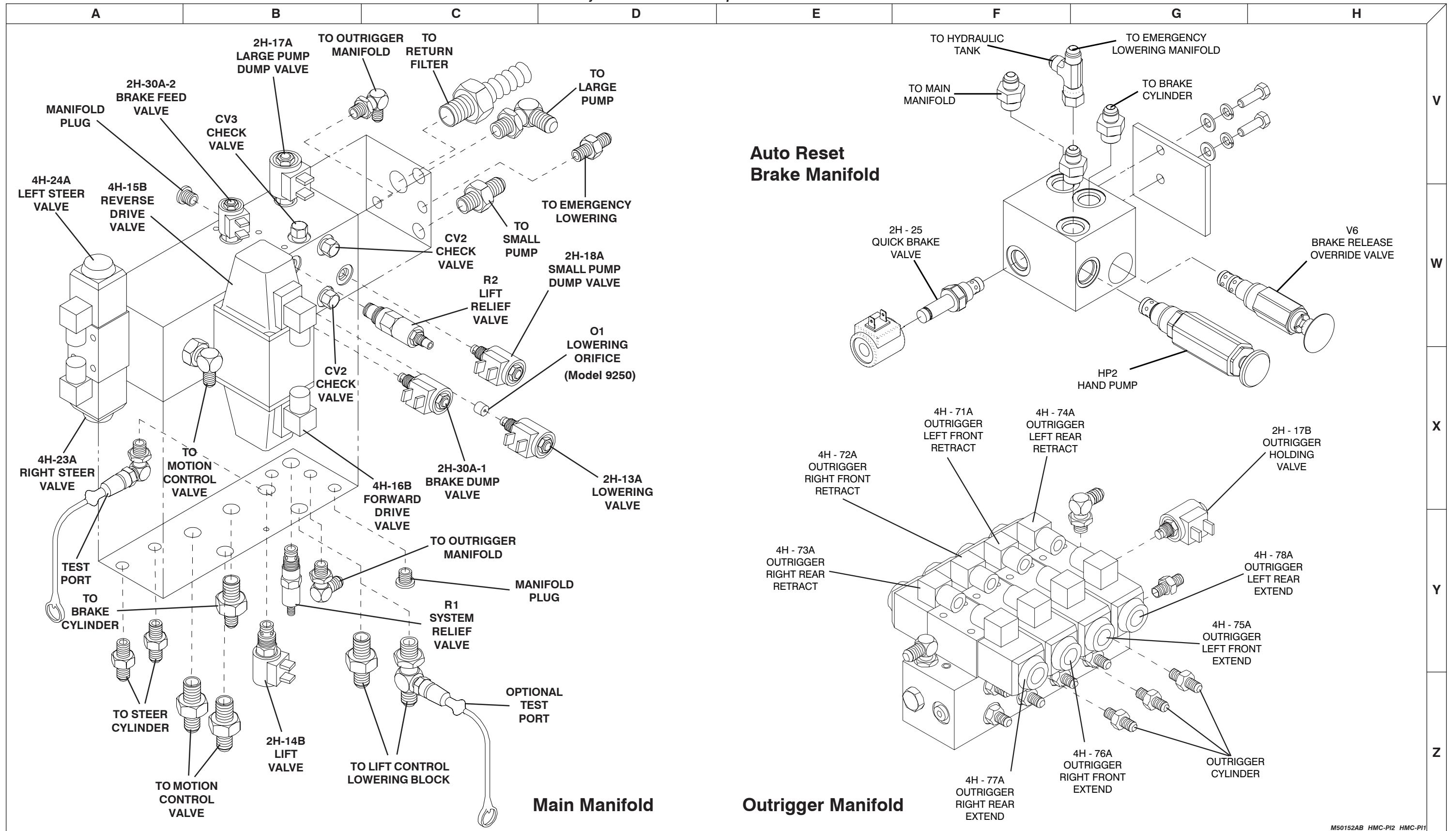

3.11 Main Manifold Wiring Diagram

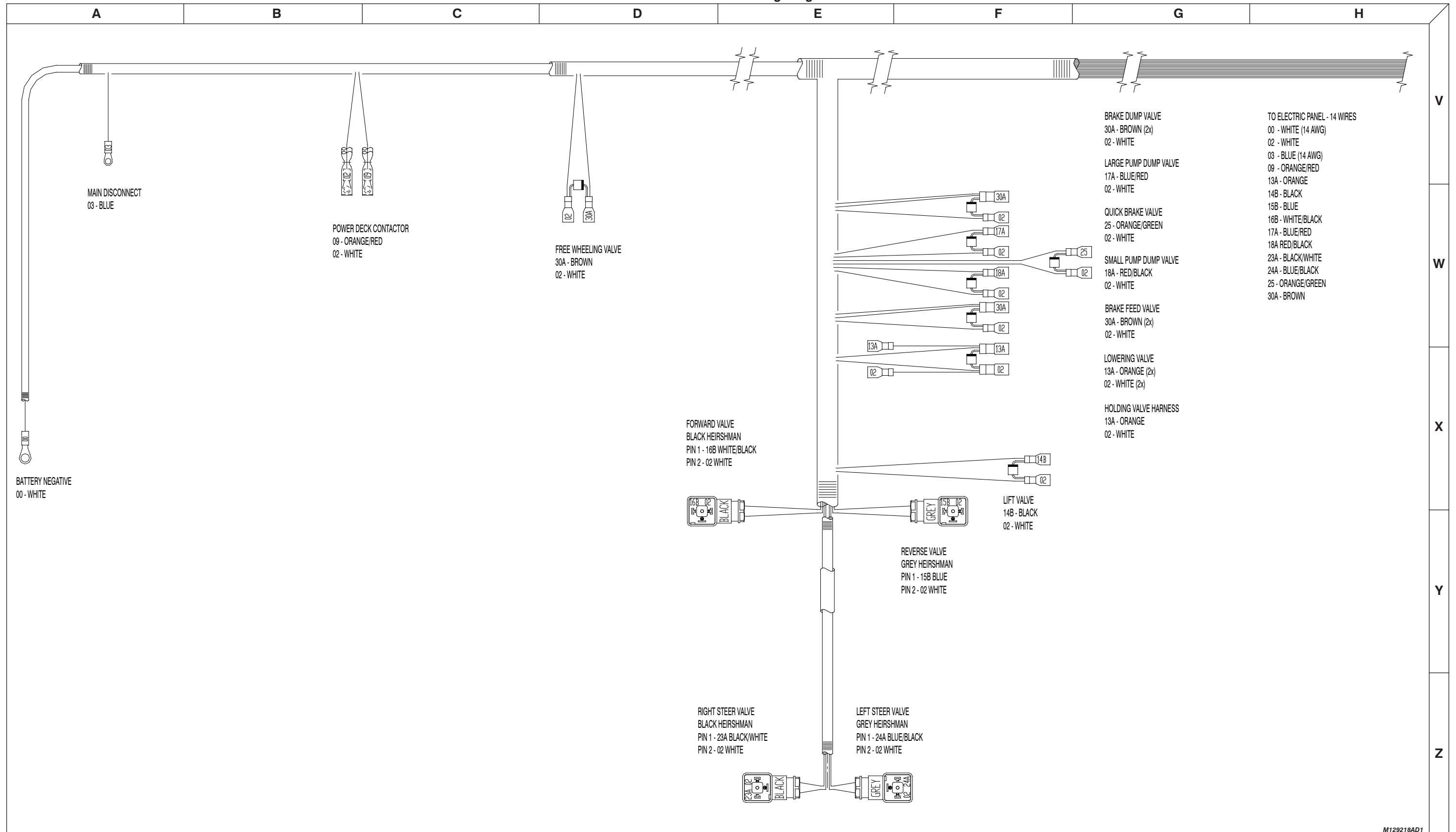

M129218AD1

3.13 Auto-Leveling Outrigger Wiring Diagram

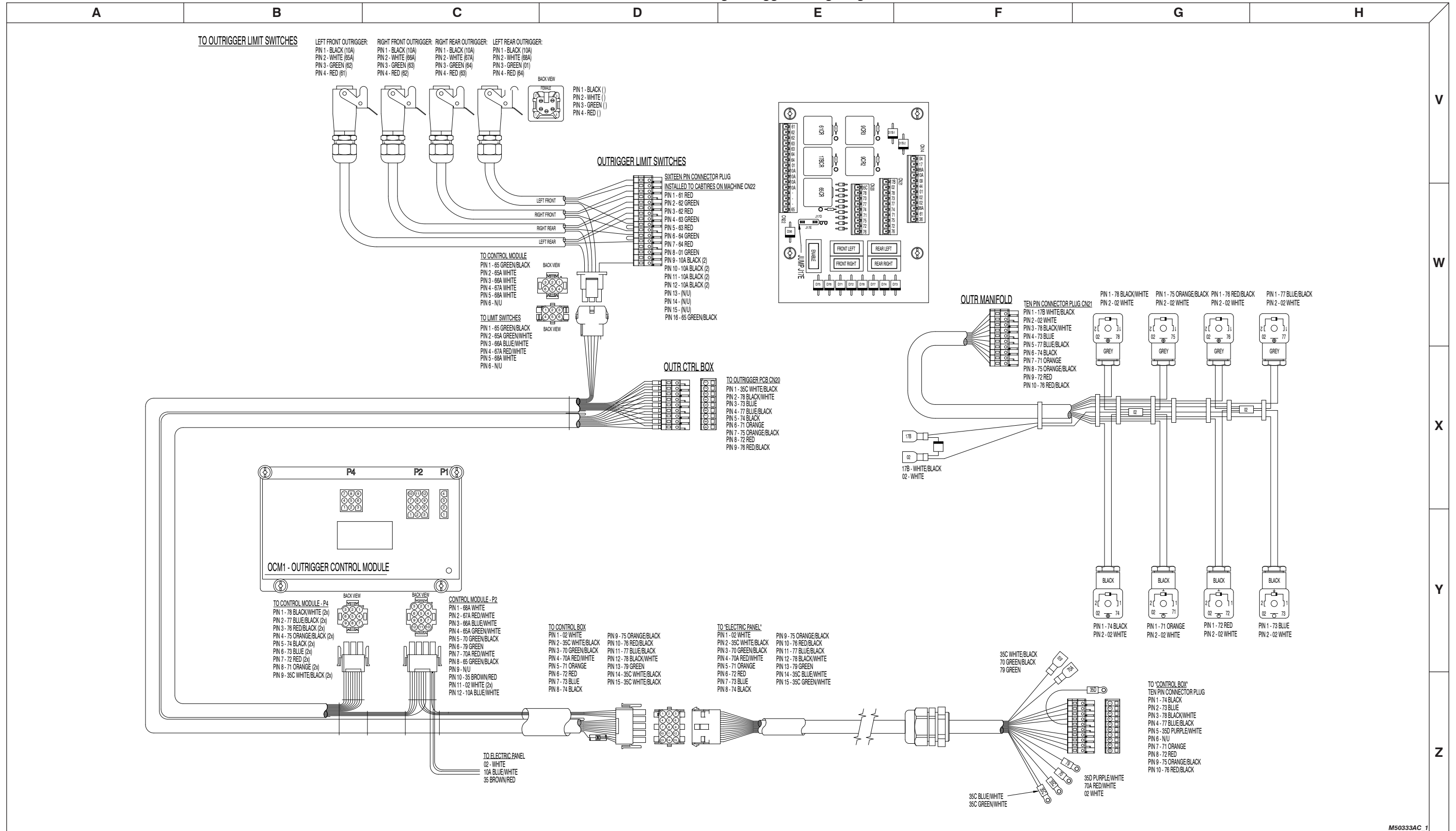

M50333AC_1

3.14 Powered Extension Platform - Electrical Wiring Diagram (Model 9250)

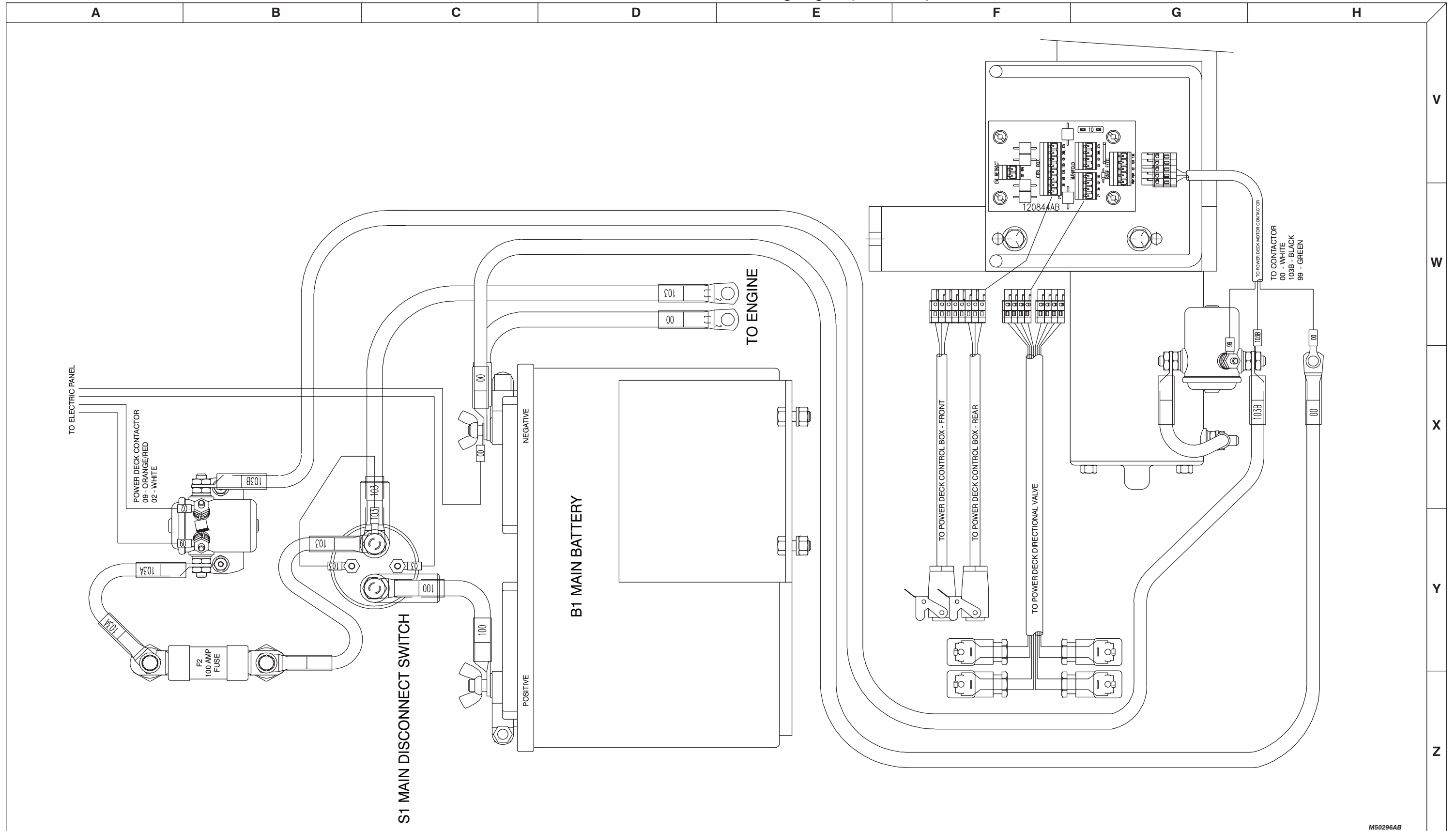

M50296AB

3.15 Horn, Light, Beeper & Transducer Wiring Diagram

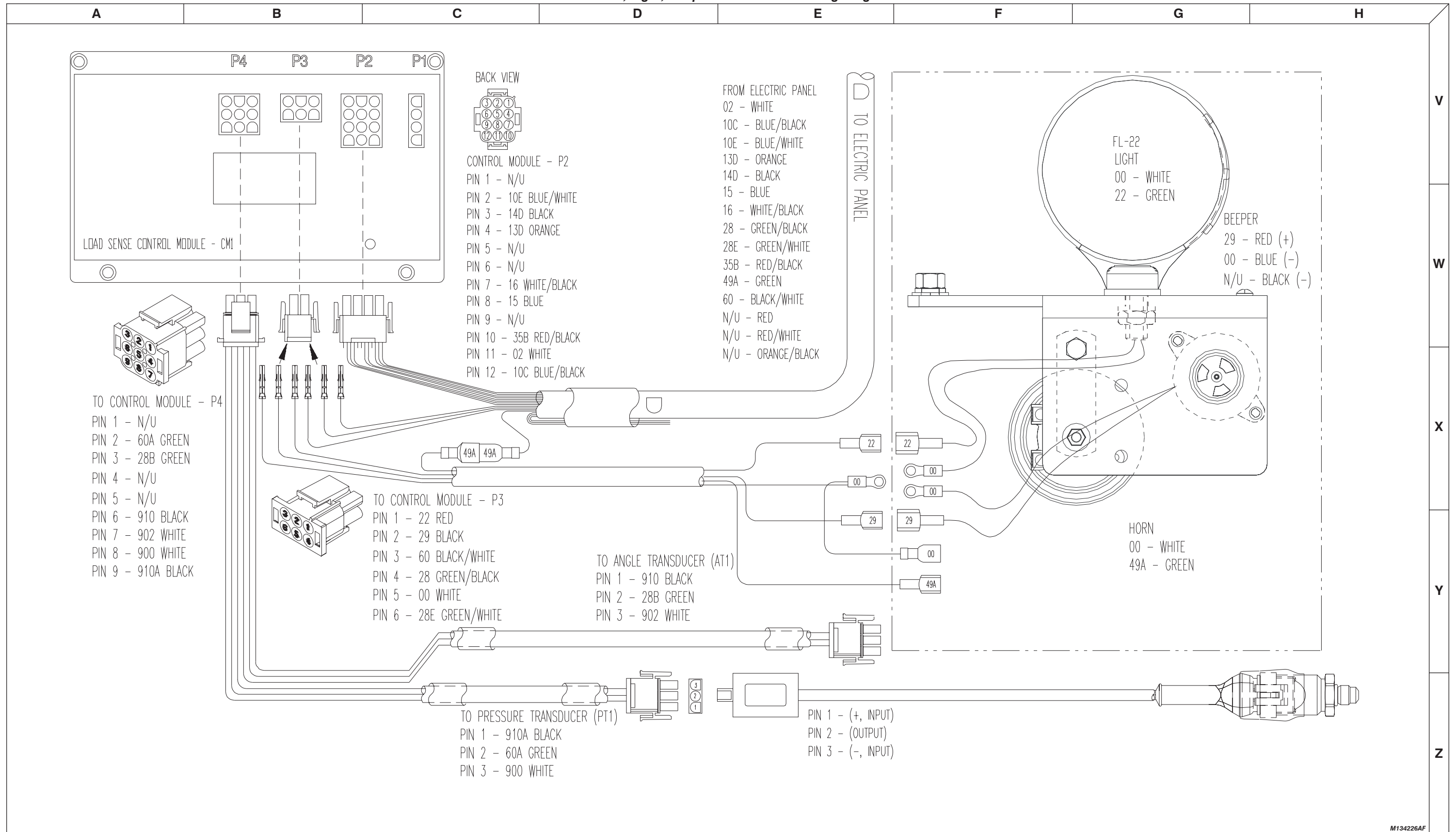

M134226AF

3.16 Electrical Panel Diagram (KC)

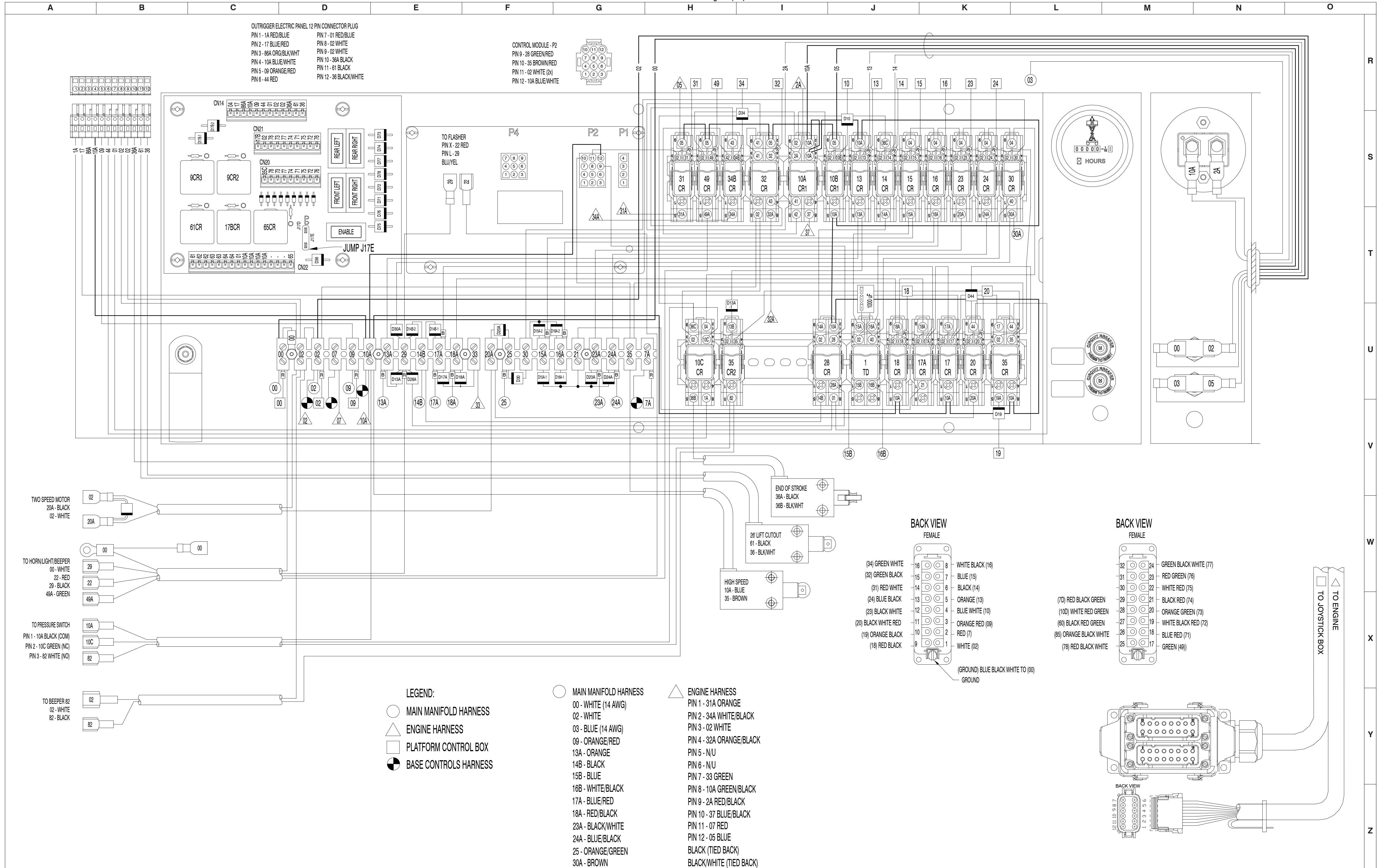

OUTRIGGER ELECTRIC PANEL 12 PIN CONNECTOR PLUG
 PIN 1 - 1A RED/BLUE
 PIN 2 - 17 BLUE/RED
 PIN 3 - 86A ORG/BLK/WHT
 PIN 4 - 10A BLUE/WHITE
 PIN 5 - 09 ORANGE/RED
 PIN 6 - 44 RED
 PIN 7 - 01 RED/BLUE
 PIN 8 - 02 WHITE
 PIN 9 - 02 WHITE
 PIN 10 - 36A BLACK
 PIN 11 - 61 BLACK
 PIN 12 - 36 BLACK/WHITE

CONTROL MODULE - P2
 PIN 9 - 28 GREEN/RED
 PIN 10 - 35 BROWN/RED
 PIN 11 - 02 WHITE (2x)
 PIN 12 - 10A BLUE/WHITE

TWO SPEED MOTOR
 20A - BLACK
 02 - WHITE

TO HORN/LIGHT/BEEPER
 00 - WHITE
 22 - RED
 29 - BLACK
 49A - GREEN

TO PRESSURE SWITCH
 PIN 1 - 10A BLACK (COM)
 PIN 2 - 10C GREEN (NC)
 PIN 3 - 82 WHITE (NO)

TO BEEPER 82
 02 - WHITE
 82 - BLACK

LEGEND:
 ○ MAIN MANIFOLD HARNESS
 △ ENGINE HARNESS
 □ PLATFORM CONTROL BOX
 ● BASE CONTROLS HARNESS

○ MAIN MANIFOLD HARNESS
 00 - WHITE (14 AWG)
 02 - WHITE
 03 - BLUE (14 AWG)
 09 - ORANGE/RED
 13A - ORANGE
 14B - BLACK
 15B - BLUE
 16B - WHITE/BLACK
 17A - BLUE/RED
 18A - RED/BLACK
 23A - BLACK/WHITE
 24A - BLUE/BLACK
 25 - ORANGE/GREEN
 30A - BROWN

△ ENGINE HARNESS
 PIN 1 - 31A ORANGE
 PIN 2 - 34A WHITE/BLACK
 PIN 3 - 02 WHITE
 PIN 4 - 32A ORANGE/BLACK
 PIN 5 - N/U
 PIN 6 - N/U
 PIN 7 - 33 GREEN
 PIN 8 - 10A GREEN/BLACK
 PIN 9 - 2A RED/BLACK
 PIN 10 - 37 BLUE/BLACK
 PIN 11 - 07 RED
 PIN 12 - 05 BLUE
 BLACK (TIED BACK)
 BLACK/WHITE (TIED BACK)

BACK VIEW FEMALE
 (34) GREEN WHITE
 (32) GREEN BLACK
 (31) RED WHITE
 (24) BLUE BLACK
 (23) BLACK WHITE
 (20) BLACK WHITE RED
 (19) ORANGE BLACK
 (18) RED BLACK
 16 WHITE BLACK (16)
 15 BLUE (15)
 14 BLACK (14)
 13 ORANGE (13)
 12 BLUE WHITE (10)
 11 ORANGE RED (09)
 10 RED (7)
 9 WHITE (02)
 (GROUND) BLUE BLACK WHITE TO (00) GROUND

BACK VIEW FEMALE
 32 GREEN BLACK WHITE (77)
 31 RED GREEN (76)
 30 WHITE RED (75)
 29 BLACK GREEN (74)
 28 ORANGE GREEN (73)
 27 WHITE BLACK RED (72)
 26 BLUE RED (71)
 25 GREEN (49)
 (70) RED BLACK GREEN
 (100) WHITE RED GREEN
 (60) BLACK RED GREEN
 (85) ORANGE BLACK WHITE
 (78) RED BLACK WHITE

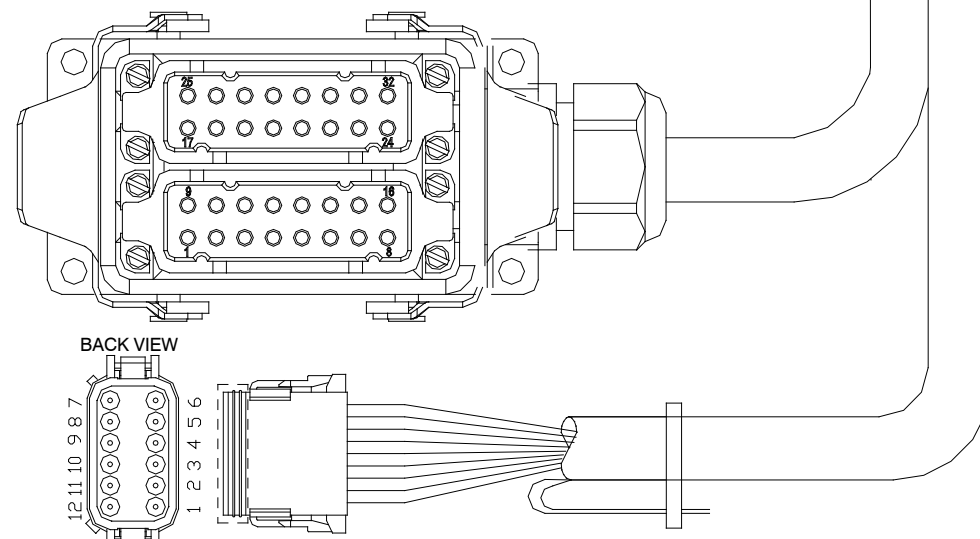

3.17 Electrical Schematic - KC (All Option with Kubota Diesel Engine)

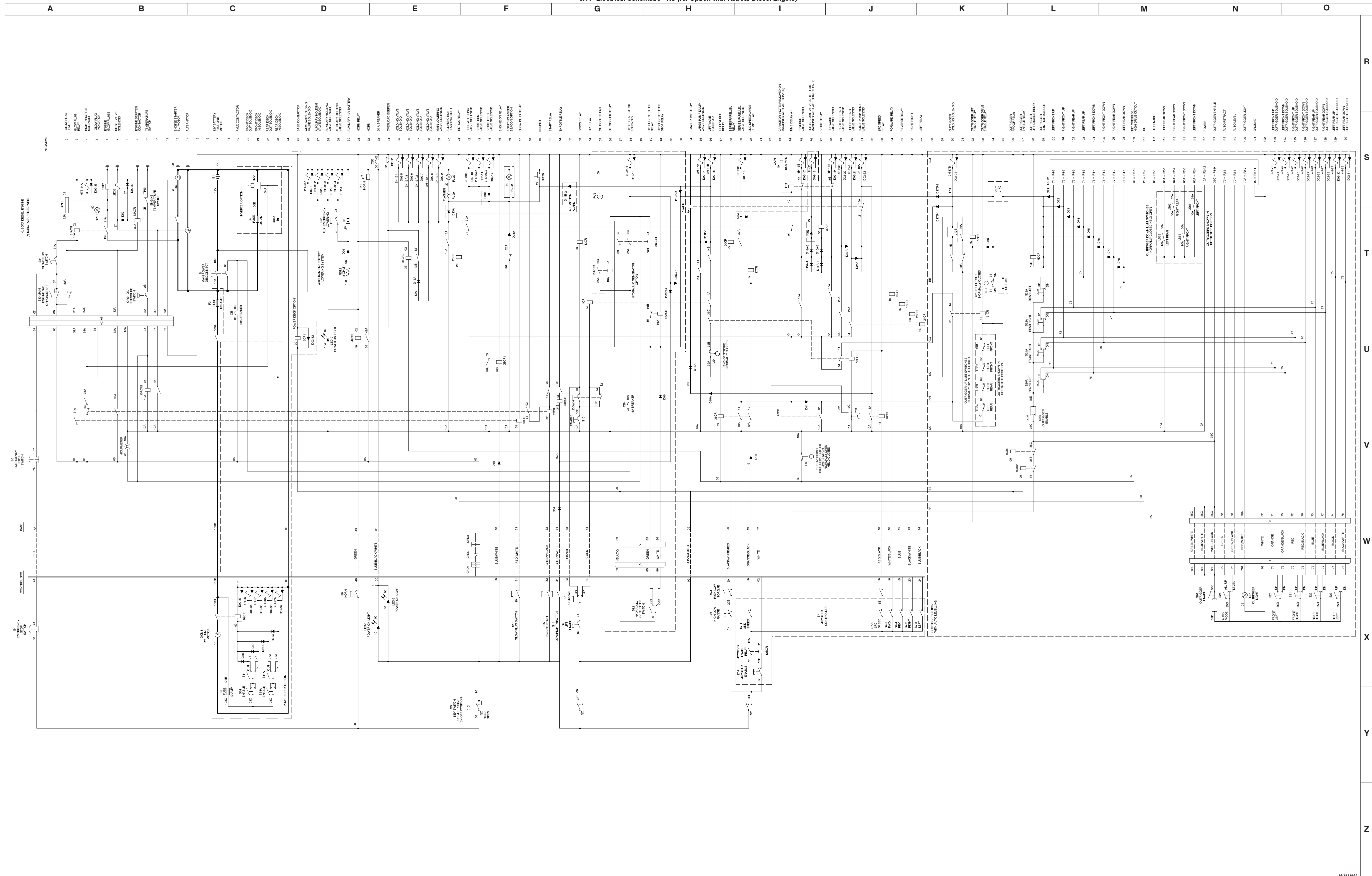

Section 4 TROUBLESHOOTING INFORMATION

Table of Contents

Introduction79

Electrical System

4.1-1 All Controls Inoperative.....80
4.1-2 No Power to Platform.....80
4.1-3 All Functions Inoperative from Platform80
4.1-4 Engine will Not Crank from Platform81
4.1-5 Engine will Not Crank from Base Controls (Kubota diesel)81
4.1-6 Engine Cranks but Stops Cranking after a few seconds81
4.1-7 Glow Plugs Inoperative from Engine Controls82
4.1-8 Glow Plugs Inoperative from Platform (Additional)82
4.1-9 Engine Cranks but will Not Start (Kubota diesel)82
4.1-10 High Throttle Inoperative82
4.1-11 Drive and Steer Inoperative83
4.1-12 Brakes will Not Release84
4.1-13 Steer Right Inoperative84
4.1-14 Steer Left Inoperative.....85
4.1-15 Reverse Drive Inoperative.....85
4.1-16 Forward Drive Inoperative.....86
4.1-17 First Drive Speed and Steering Inoperative86
4.1-18 Second Drive Speed Inoperative.....87
4.1-19 Third Drive Speed Inoperative88
4.1-20 High/Low Range Speed Inoperative88
4.1-21 Up Circuit Inoperative from Platform or Base.....89
4.1-22 Platform will Not Lift from Platform or Base Controls with Outriggers Extended90
4.1-23 Platform will Not Lift from Platform or Base Controls with Outriggers Retracted
(lift operates correctly with outriggers extended).....91
4.1-24 Up Circuit Inoperative from Base91
4.1-25 Down Circuit Inoperative from Platform or Base.....92
4.1-26 Down Circuit Inoperative from Base.....92
4.1-27 Powered Extension Platform Inoperative93
4.1-28 Powered Extension Platform will Not Extend93
4.1-29 Powered Extension Platform will Not Retract94
4.1-30 Hydraulic Generator Inoperative94
4.1-31 Hydraulic Generator will Not Shut Off from Generator Switch.....95
4.1-32 All Outriggers Inoperative (Auto-level and manual)95
4.1-33 All Outriggers Inoperative (Auto-level and manual from platform controls)95
4.1-34 All Outriggers Inoperative (Base Controls).....96
4.1-35 All Outriggers Inoperative (Auto-level)
A: Led Power Indicator Light at Outrigger Control Module (OCM1) Not on Constant.....96
4.1-36 All Outriggers Inoperative (Auto Level)
B: Led Power Indicator Light at Outrigger Control Module (OCM1) Flashing.....97
4.1-37 Left Front Outrigger Inoperative Manually98
4.1-38 Right Front Outrigger Inoperative Manually98
4.1-39 Right Rear Outriggers Inoperative Manually98
4.1-40 Left Rear Outriggers Inoperative Manually98



Table of Contents (Continued)

4.1-41 Individual Outrigger Functions Inoperative (Auto-level)	99
4.1-42 Auto-level Inoperative	99
4.1-43 Auto All Up Inoperative (Retract)	99

Hydraulic System

4.2-1 All Functions Inoperative	100
4.2-2 Steering Inoperative.....	100
4.2-3 Steer and First Drive Speed Inoperative	100
4.2-4 Lift and Second Drive Speed Inoperative.....	100
4.2-5 Drive Inoperative	100
4.2-6 Reverse Drive Inoperative.....	101
4.2-7 Forward Drive Inoperative.....	101
4.2-8 Brakes will Not Release	101
4.2-9 Brakes will Not Release (Internal Brake)	101
4.2-10 Brake Slips (Internal Brake).....	101
4.2-11 Brake Drags or Runs Hot (Internal Brake).....	102
4.2-12 Up Circuit Inoperative	102
4.2-13 Down Circuit Inoperative	102
4.2-14 Powered Extension Platform Inoperative	102
4.2-15 Hydraulic Generator Inoperative	102
4.2-16 All Outriggers Inoperative	103
4.2-17 Left Front Outrigger Inoperative	103
4.2-18 Right Front Outrigger Inoperative.....	103
4.2-19 Right Rear Outrigger Inoperative.....	103
4.2-20 Left Rear Outrigger Inoperative	103
4.2-21 Outriggers Drift In	103

Introduction

The following pages contain a table of Troubleshooting Information for locating and correcting most service trouble which can develop. Careful and accurate analysis of the systems listed in the table of Troubleshooting Information will localize the trouble more quickly than any other method. This manual cannot cover all possible troubles and deficiencies that may occur. If a specific trouble is not listed, isolate the major component in which the trouble occurs, isolate whether the problem is electrical or hydraulic, and then isolate and correct the specific problem.

The content of this section is separated into “probable cause” and “remedy.” The information preceded by a number represents the “probable cause.” The following line, noted by a dash represents the “remedy” to the “probable cause” directly above it. See example below for clarification.

1. Probable Cause
 - [Remedy](#)

Electrical System

4.1-1 All Controls Inoperative

1. Battery disconnected or discharged.
 - Reconnect battery. Recharge if discharged.
2. Loose or dirty battery cables.
 - Clean and tighten battery cables.
3. Open or defective main power disconnect switch S1.
 - Close switch. Replace if defective.
4. Loose or broken wire #03 from main power disconnect switch S1 to circuit breaker CB1.
 - Check continuity. Replace if defective.
5. Tripped or defective circuit breaker CB1.
 - Reset breaker. Check for defective wiring. Replace breaker if defective.
6. Loose or broken wire #05 from breaker CB1 to relay 10BCR1.
 - Check continuity. Replace if defective.
7. Loose or broken wire #05 from relay 31CR to base engine switch S30.
 - Check continuity. Replace if defective.
8. Loose or broken wire #00 from battery B1 to base terminal block TB-1.
 - Check continuity. Replace if defective.
9. Loose or broken wire #00 from base terminal block TB-1 to circuit breaker CB3.
 - Check continuity. Replace if defective.
10. Tripped or defective circuit breaker CB3.
 - Reset breaker. Check for defective wiring. Replace breaker if defective.
11. Loose or broken wire #02 from circuit breaker CB3 to base terminal block TB-1.
 - Check continuity. Replace if defective.

4.1-2 No Power to Platform

1. Open or defective base engine switch S30.
 - Check switch. Replace if defective.
2. Loose or broken wire #07 from base engine switch S30 to base terminal block TB-1.
 - Check continuity. Replace if defective.
3. Loose or broken wire #07 from base terminal block TB-1 to emergency stop switch S6.
 - Check continuity. Replace if defective.
4. Open or defective emergency stop switch S6.
 - Check switch. Replace if defective.
5. Loose or broken wire #7A from emergency stop switch S6 to base terminal block TB-1.
 - Check continuity. Replace if defective.
6. Loose or broken wire #7A from base terminal block TB-1 to emergency stop switch S4.
 - Check continuity. Replace if defective.
7. Open or defective emergency stop switch S4.
 - Check switch. Replace if defective.

4.1-3 All Functions Inoperative from Platform

1. Loose or broken wire #08 from emergency stop switch S4 to off/lift/drive key switch S3.
 - Check continuity. Replace if defective.
2. Open or defective off/lift/drive key switch S3.
 - Check switch. Replace if defective.
3. Loose or broken wire #10 from off/lift/drive key switch S3 to platform terminal block.
 - Check continuity. Replace if defective.
4. Loose or broken wire #10 from platform terminal block to diode D10 located at relay 10BCR1.
 - Check continuity. Replace if defective.
5. Open diode D10 or diode D10 is not connected at relay 10BCR1.
 - Check diode. Replace if defective.

Electrical System (Continued)

4.1-4 Engine will Not Crank from Platform

1. Open or defective key switch S3.
 - Check switch. Replace if defective.
2. Loose or broken wire #10 from key switch S3 to start switch S15.
 - Check continuity. Replace if defective.
3. Defective start switch S15.
 - Check switch. Replace if defective.
4. Loose or broken wire #32 from start switch S15 to relay 32CR.
 - Check continuity. Replace if defective.
5. Defective relay 32CR.
 - Check relay. Replace if defective.
6. Loose or broken wire #41 from relay 32CR to relay 10ACR1.
 - Check continuity. Replace if defective.
7. Loose or broken wire #02 from relay 10ACR1 to base terminal block.
 - Check continuity. Replace if defective.
8. Loose or broken wire #05 from base terminal block to relay 32CR.
 - Check continuity. Replace if defective.
9. Loose or broken wire #32A from relay 32CR to starter contactor 32ACR.
 - Check continuity. Replace if defective.
10. Defective starter contactor 32ACR.
 - Check contactor. Replace if defective.
11. Loose or broken wire #00 from starter contactor 32ACR to engine ground.
 - Check continuity. Replace if defective.
12. Loose or broken wire #103 from main power disconnect switch S1 to starter contactor 32ACR. (Kubota Diesel)
 - Check continuity. Replace if defective.
13. Loose or broken wire #104 from starter contactor 32ACR to starter motor. (Kubota Diesel)
 - Check continuity. Replace if defective.
14. Defective starter motor.
 - Check motor. Repair or replace if defective.

4.1-5 Engine will Not Crank from Base Controls (Kubota diesel)

1. Loose or broken wire #05 from base terminal block to base engine switch S30.
 - Check continuity. Replace if defective.
2. Loose or broken jumper wire #05 on base engine switch S30.
 - Check continuity. Replace if defective.
3. Defective engine start switch S30.
 - Check switch. Replace if defective.
4. Loose or broken wire #32A from engine start switch S30 to starter contactor 32ACR.
 - Check continuity. Replace if defective.

4.1-6 Engine Cranks but Stops Cranking after a few seconds

1. Loose or broken jumper wire #41 on relay 32CR.
 - Check continuity. Replace if defective.
2. Loose or broken wire #02 from relay 32CR to base terminal block TB-1.
 - Check continuity. Replace if defective.

Electrical System (Continued)

4.1-7 Glow Plugs Inoperative from Engine Controls

1. Loose or broken wire #07 from engine start switch S30 to glow plug switch S31.
 - Check continuity. Replace if defective.
2. Defective glow plug switch S31.
 - Check switch. Replace if defective.
3. Loose or broken wire #31A from glow plug switch S31 to glow plug relay 31ACR.
 - Check continuity. Replace if defective.
4. Loose or broken wire #02 from glow plug relay 31ACR to base terminal block TB1.
 - Check continuity. Replace if defective.
5. Loose or broken wire #103 from starter solenoid 32ACR to relay 31ACR.
 - Check continuity. Replace if defective.
6. Loose or broken wire #91A from relay 31ACR to engine glow plugs EGP1.
 - Check continuity. Replace if defective.
7. Defective glow plug relay 31ACR.
 - Check relay. Replace if defective.
8. Defective glow plugs.
 - Check glow plugs. Replace if defective.

4.1-8 Glow Plugs Inoperative from Platform (Additional)

1. Loose or broken wire #10 from key selector switch S3 to glow plug switch S13.
 - Check continuity. Replace if defective.
2. Defective glow plug switch S13.
 - Check switch. Replace if defective.
3. Loose or broken wire #31 from glow plug switch S13 to glow plug relay 31CR.
 - Check continuity. Replace if defective.
4. Loose or broken wire #02 from relay 31CR to base terminal block TB1.
 - Check continuity. Replace if defective.
5. Loose or broken wire #05 from base terminal block TB1 to relay 31CR.
 - Check continuity. Replace if defective.
6. Loose or broken wire #31A from relay 31CR to glow plug relay 31ACR.
 - Check continuity. Replace if defective.
7. Defective relay 31CR.
 - Check relay. Replace if defective.

4.1-9 Engine Cranks but will Not Start (Kubota diesel)

1. Loose or broken wire #37 from base terminal block to diesel valve solenoid 2D37.
 - Check continuity. Replace if defective.
2. Loose or broken wire #57 from starter contactor 32ACR to diesel valve solenoid 2D37.
 - Check continuity. Replace if defective.
3. Defective fuel valve solenoid 2D37.
 - Check solenoid. Replace if defective.
4. Defective glow plug circuit.
 - See glow plugs inoperative above. Repair if necessary.

4.1-10 High Throttle Inoperative

1. Loose or broken wire #10 from key switch S3 to high/low throttle switch S14.
 - Check continuity. Replace if defective.
2. Defective high/low throttle switch S14.
 - Check switch. Replace if defective.
3. Loose or broken wire #34 from high/low throttle switch S14 to diode D34 at relay 34BCR.
 - Check continuity. Replace if defective.

Electrical System (Continued)

4. Open or loose diode D34.
 - Check diode. Replace if defective.
5. Loose or broken wire #34B from base terminal block TB-1 to relay 34BCR. (CE only)
 - Check continuity. Replace if defective.
6. Defective relay 34BCR.
 - Check relay. Replace if defective.
7. Loose or broken wire #42 from relay 34BCR to relay 10ACR1.
 - Check continuity. Replace if defective.
8. Defective relay 10ACR1.
 - Check relay. Replace if defective.
9. Loose or broken wire #02 from relay 10ACR1 to base terminal block TB1.
 - Check continuity. Replace if defective.
10. Loose or broken wire #05 from base terminal block TB1 to relay 32CR.
 - Check continuity. Replace if defective.
11. Defective relay 32CR.
 - Check relay. Replace if defective.
12. Loose or broken wire #43 from relay 32CR to relay 34BCR.
 - Check continuity. Replace if defective.
13. Loose or broken wire #34A from relay 34BCR to engine harness plug.
 - Check continuity. Replace if defective.
14. Loose or broken wire #34A from engine harness plug to high throttle solenoid HTS-34A.
 - Check continuity. Replace if defective.

4.1-11 Drive and Steer Inoperative

1. Outriggers not fully retracted
 - Fully retract outrigger cylinders
2. Key switch S3 in lift position.
 - Turn switch to drive position.
3. Defective drive contacts in key switch S3.
 - Check contacts. Replace if defective.
4. Loose or broken wire #12 from key switch S3 to joystick enable switch S7-7.
 - Check continuity. Replace if defective.
5. Defective joystick enable switch S7-7.
 - Check switch. Replace if defective.
6. Loose or broken wire #12A from joystick enable relay 12BCR to speed, steer and direction switches S7-1 to S7-6.
 - Check continuity. Replace if defective.
7. Loose or broken wire #12B from joystick enable switch S7-7 to joystick enable relay 12BCR.
 - Check continuity. Replace if defective.
8. Defective joystick enable relay 12BCR.
 - Check continuity. Replace if defective.
9. Loose or broken wire #02 from joystick enable relay 12BCR to controller harness.
 - Check continuity. Replace if defective.
10. Loose or broken wire #10A from base terminal block to relay 28CR.
 - Check continuity. Replace if defective.
11. Defective relay 28CR.
 - Check relay. Replace if defective.
12. Loose or broken wire #1 from relay 28CR to pin #7 on connector CN14 at the outrigger board.
 - Check continuity. Replace if defective.
13. Left rear outrigger limit switch LS64 is out of adjustment or defective.
 - Check continuity through switch. Adjust switch if out of adjustment. Replace if defective.

Electrical System (Continued)

14. Right rear outrigger limit switch LS63 is out of adjustment or defective.
 - Check continuity through switch. Adjust switch if out of adjustment. Replace if defective.
15. Right front outrigger limit switch LS62 is out of adjustment or defective.
 - Check continuity through switch. Adjust switch if out of adjustment. Replace if defective.
16. Left front outrigger limit switch LS61 is out of adjustment or defective.
 - Check continuity through switch. Adjust switch if out of adjustment. Replace if defective.
17. Defective drive enable relay 61CR.
 - Check relay. Replace if defective.
18. Loose or broken wire #4 from pin #1 on connector CN14 at the outrigger board to relay 30CR.
 - Check continuity. Replace if defective.

4.1-12 Brakes will Not Release

1. Loose or broken wire #30 from diodes D15A-2 and D16A-2 to relay 30CR.
 - Check continuity. Replace if defective.
2. Defective relay 30CR.
 - Check relay. Replace if defective.
3. Loose or broken wire #02 from relay 30CR to base terminal block TB-1.
 - Check continuity. Replace if defective.
4. Loose or broken wire #4 from pin #1 on plug CN14 at outrigger board to relay 30CR.
 - Check continuity. Replace if defective.
5. Loose or broken wire #30A from relay 30CR to brake dump valve 2H-30A-1 or brake feed valve 2H-30A-2.
 - Check continuity. Replace if defective.
6. Defective valve coil brake dump 2H-30A-1 or brake feed 2H-30A-2.
 - Check continuity through coil. Replace if defective.
7. Loose or broken wire #02 from valve coil brake dump 2H-30A-1 or brake feed 2H-30A-2 to base terminal block TB-1.
 - Check continuity. Replace if defective.
8. Open diode D30.
 - Check diode. Replace if defective.
9. Loose or broken wire #25 from diode D30 to base terminal block TB-1. (Internal Brakes only)
 - Check continuity. Replace if defective.
10. Loose or broken wire #25 from base terminal block TB-1 to quick brake valve coil 2H-25. (Internal Brakes only)
 - Check continuity. Replace if defective.
11. Defective quick brake valve coil 2H-25. (Internal Brakes only)
 - Check continuity through coil. Replace if defective.
12. Loose or broken wire #02 from quick brake valve 2H-25 to base terminal block TB-1. (Internal Brakes only)
 - Check continuity. Replace if defective.

4.1-13 Steer Right Inoperative

1. Defective steer right switch S7-2 in joystick S7.
 - Check switch. Replace if defective.
2. Loose or broken wire #23 from steer right switch S7-2 to platform terminal block.
 - Check continuity. Replace if defective.
3. Loose or broken wire #23 from platform terminal block to relay 23CR.
 - Check continuity. Replace if defective.
4. Defective relay 23CR.
 - Check relay. Replace if defective.
5. Loose or broken wire #04 from base terminal block to relay 23CR.
 - Check continuity. Replace if defective.

Electrical System (Continued)

6. Loose or broken wire #23A from relay 23CR to base terminal block.
 - Check continuity. Replace if defective.
7. Loose or broken wire #02 from relay 23CR to base terminal block.
 - Check continuity. Replace if defective.
8. Loose or broken wire #23A from base terminal block to steer right valve coil 4H-23A.
 - Check continuity. Replace if defective.
9. Defective steer right valve coil 4H-23A.
 - Check coil. Replace if defective.
10. Loose or broken wire #02 from steer right valve coil 4H-23A to base terminal block.
 - Check continuity. Replace if defective.
11. Open diode D23A.
 - Check diode. Replace if defective.

4.1-14 Steer Left Inoperative

1. Defective steer left switch S7-3 in joystick S7.
 - Check switch. Replace if defective.
2. Loose or broken wire #24 from steer left switch S7-3 to platform terminal block.
 - Check continuity. Replace if defective.
3. Loose or broken wire #24 from platform terminal block to relay 24CR.
 - Check continuity. Replace if defective.
4. Defective relay 24CR.
 - Check relay. Replace if defective.
5. Loose or broken wire #04 from base terminal block to relay 24CR.
 - Check continuity. Replace if defective.
6. Loose or broken wire #24A from relay 24CR to base terminal block.
 - Check continuity. Replace if defective.
7. Loose or broken wire #02 from relay 24CR to base terminal block.
 - Check continuity. Replace if defective.
8. Loose or broken wire #24A from base terminal block to steer left valve coil 4H-24A.
 - Check continuity. Replace if defective.
9. Defective steer left valve coil 4H-24A.
 - Check coil. Replace if defective.
10. Loose or broken wire #02 from steer left valve coil 4H-24A to base terminal block.
 - Check continuity. Replace if defective.
11. Open diode D24A.
 - Check diode. Replace if defective.

4.1-15 Reverse Drive Inoperative

1. Defective drive reverse switch S7-4 in joystick S7.
 - Check switch. Replace if defective.
2. Defective joystick S7.
 - Check joystick. Replace if defective.
3. Loose or broken wire #15 from joystick S7 to platform terminal block.
 - Check continuity. Replace if defective.
4. Loose or broken wire #15 from platform terminal block to relay 15CR.
 - Check continuity. Replace if defective.
5. Defective relay 15CR.
 - Check relay. Replace if defective.
6. Loose or broken wire #02 from relay 15CR to base terminal block.
 - Check continuity. Replace if defective.

Electrical System (Continued)

7. Loose or broken wire #04 from base terminal block to relay 15CR.
 - Check continuity. Replace if defective.
8. Loose or broken wire #15A from relay 15CR to time delay relay 1TD.
 - Check continuity. Replace if defective.
9. Defective time delay relay 1TD.
 - Check relay. Replace if defective.
10. Loose or broken wire #15B from time delay relay 1TD to reverse valve coil 4H-15B.
 - Check continuity. Replace if defective.
11. Defective reverse valve coil 4H-15B.
 - Check coil. Replace if defective.
12. Loose or broken wire #02 from reverse valve coil 4H-15B to base terminal block.
 - Check continuity. Replace if defective.
13. Open diode D15A-1 or D15A-2.
 - Check diodes. Replace if defective.

4.1-16 Forward Drive Inoperative

1. Defective drive forward switch S7-5 in joystick S7.
 - Check switch. Replace if defective.
2. Defective joystick S7.
 - Check joystick. Replace if defective.
3. Loose or broken wire #16 from joystick S7 to platform terminal block.
 - Check continuity. Replace if defective.
4. Loose or broken wire #16 from platform terminal block to relay 16CR.
 - Check continuity. Replace if defective.
5. Defective relay 16CR.
 - Check relay. Replace if defective.
6. Loose or broken wire #02 from relay 16CR to base terminal block.
 - Check continuity. Replace if defective.
7. Loose or broken wire #04 from base terminal block to relay 16CR.
 - Check continuity. Replace if defective.
8. Loose or broken wire #16A from relay 16CR to time delay relay 1TD.
 - Check continuity. Replace if defective.
9. Defective time delay relay 1TD.
 - Check relay. Replace if defective.
10. Loose or broken wire #16B from time delay relay 1TD to forward valve coil 4H-16B.
 - Check continuity. Replace if defective.
11. Defective forward valve coil 4H-16B.
 - Check coil. Replace if defective.
12. Loose or broken wire #02 from forward valve coil 4H-16B to base terminal block.
 - Check continuity. Replace if defective.
13. Open diode D16A-1 or D16A-2.
 - Check diodes. Replace if defective.

4.1-17 First Drive Speed and Steering Inoperative

1. Loose or broken wire #21 from base terminal block to relay 17ACR.
 - Check continuity. Replace if defective.
2. Defective relay 17ACR.
 - Check relay. Replace if defective.
3. Loose or broken wire #18A from relay 17ACR to small pump dump valve solenoid 2H-18A.
 - Check continuity. Replace if defective.

Electrical System (Continued)

4. Defective small pump dump valve coil 2H-18A.
 - Check coil. Replace if defective.
5. Loose or broken wire #02 from small pump dump solenoid 2H-18A to base terminal block.
 - Check continuity. Replace if defective.

4.1-18 Second Drive Speed Inoperative

1. Defective second speed switch S7-1 in joystick S7.
 - Check switch. Replace if defective.
2. Defective joystick S7.
 - Check joystick. Replace if defective.
3. Loose or broken wire #19 from controller S7-1 to platform terminal block.
 - Check continuity. Replace if defective.
4. Loose or broken wire #19 from platform terminal block to diode D19 at relay 35CR.
 - Check continuity. Replace if defective.
5. Loose or Open diode D19.
 - Tighten diode. Check diode. Replace if defective.
6. Loose or broken wire #10A from base terminal block to high drive/tilt override limit switch LS5.
 - Check continuity. Replace if defective.
7. Misadjusted or defective high drive/tilt override limit switch LS5.
 - Adjust switch. Replace if defective.
8. Loose or broken wire #35 from high drive/tilt override limit switch LS5 to base terminal block.
 - Check continuity. Replace if defective.
9. Loose or broken wire #35 from base terminal block to relay 35CR.
 - Check continuity. Replace if defective.
10. Loose or broken wire #02 from relay 35CR to base terminal block.
 - Check continuity. Replace if defective.
11. Defective relay 35CR.
 - Check relay. Replace if defective.
12. Loose or broken wire #17 from relay 35CR to relay 17CR.
 - Check continuity. Replace if defective.
13. Defective relay 17CR.
 - Check relay. Replace if defective.
14. Loose or broken wire #02 from relay 17CR to base terminal block.
 - Check continuity. Replace if defective.
15. Loose or broken wire #10A from base terminal block to relay 17CR.
 - Check continuity. Replace if defective.
16. Loose or broken wire #17A from relay 17CR to base terminal block.
 - Check continuity. Replace if defective.
17. Loose or broken wire #17A from relay 17CR to relay 17ACR.
 - Check continuity. Replace if defective.
18. Defective relay 17ACR.
 - Check relay. Replace if defective.
19. Loose or broken wire #02 from relay 17ACR to base terminal block.
 - Check continuity. Replace if defective.
20. Loose or broken wire #17A from base terminal block to large pump dump valve solenoid 2H-17A.
 - Check continuity. Replace if defective.
21. Loose or broken wire #02 from large pump dump valve solenoid 2H-17A to base terminal block.
 - Check continuity. Replace if defective.
22. Defective large pump dump valve solenoid 2H-17A.
 - Check solenoid. Replace if defective.

Electrical System (Continued)

4.1-19 Third Drive Speed Inoperative

1. High/Low torque switch S41 in high torque position or defective.
 - Turn high/low torque switch to low torque position. Replace if defective.
2. Defective third speed switch S7-6 in joystick S7.
 - Check switch. Replace if defective.
3. Defective joystick S7.
 - Check joystick. Replace if defective.
4. Loose or broken wire #18B from controller S7-6 to low/high torque switch S41.
 - Check continuity. Replace if defective.
5. Loose or broken wire #18 from low/high torque switch S41 to platform terminal block.
 - Check continuity. Replace if defective.
6. Loose or broken wire #18 from platform terminal block to relay 18CR.
 - Check continuity. Replace if defective.
7. Defective relay 18CR.
 - Check relay. Replace if defective.
8. Loose or broken wire #02 from relay 18CR to base terminal block.
 - Check continuity. Replace if defective.
9. Loose or broken wire #10A from base terminal block to relay 18CR.
 - Check continuity. Replace if defective.
10. Loose or broken wire #18A from relay 18CR to small pump dump valve 2H-18A.
 - Check continuity. Replace if defective.
11. Loose or broken wire #02 from small pump dump valve 2H-18A to base terminal block.
 - Check continuity. Replace if defective.
12. Defective small pump dump valve solenoid 2H-18A.
 - Check solenoid. Replace if defective.

4.1-20 High/Low Range Speed Inoperative

1. Loose or broken wire #12 from joystick enable switch S7-7 to high/low range switch S29.
 - Check continuity. Replace if defective.
2. Defective high/low range switch S29.
 - Check switch. Replace if defective.
3. Loose or broken wire #20B from high/low range switch S29 to high/low torque switch S41.
 - Check continuity. Replace if defective.
4. Defective high/low torque switch S41.
 - Check switch. Replace if defective.
5. Loose or broken wire #20 from high/low torque switch S41 to relay 20CR.
 - Check continuity. Replace if defective.
6. Defective relay 20CR.
 - Check relay. Replace if defective.
7. Loose or broken wire #02 from relay 20CR to base terminal block.
 - Check continuity. Replace if defective.
8. Loose or broken wire #10A from base terminal block to relay 35CR.
 - Check continuity. Replace if defective.
9. Defective relay 35CR.
 - Check relay. Replace if defective.
10. Loose or broken wire #44 from relay 35CR to relay 20CR.
 - Check continuity. Replace if defective.
11. Loose or broken wire #20A from relay 20CR to base terminal block TB-1.
 - Check continuity. Replace if defective.
12. Loose or broken wire #20A from base terminal block to series parallel valve coil 3H-20A.
 - Check continuity. Replace if defective.

Electrical System (Continued)

13. Defective series/parallel valve coil 3H-20A.
 - Check coil. Replace if defective.
14. Loose or broken wire #02 from series/parallel valve coil 3H-20A to base terminal block.
 - Check continuity. Replace if defective.

4.1-21 Up Circuit Inoperative from Platform or Base

1. Lift/Off/Drive switch S3 in drive position or defective.
 - Select lift position. Check switch. Replace if defective.
2. Loose or broken wire #09 from lift/off/drive switch S3 to lift enable switch S9.
 - Check continuity. Replace if defective.
3. Defective lift enable switch S9.
 - Check switch. Replace if defective.
4. Loose or broken wire #9A from enable switch S9 to up/down switch S5.
 - Check continuity. Replace if defective.
5. Defective up/down switch S5.
 - Check switch. Replace if defective.
6. Loose or broken wire #14 from up/down switch S5 to relay 14CR. (ANSI/CSA)
 - Check continuity. Replace if defective.
10. Loose or broken wire #02 from relay 14CR to base terminal block.
 - Check continuity. Replace if defective.
11. Defective relay 14CR.
 - Check relay. Replace if defective.
12. Loose or broken wire #36A from pin #10 on connector CN14 at the outrigger board to terminal block TB-1.
 - Check continuity. Replace if defective.
13. Loose or broken wire #36A from terminal block TB-1 to end of stroke limit switch LS4.
 - Check continuity. Replace if defective.
14. Defective end of stroke limit switch LS4.
 - Check switch. Replace if defective.
15. Loose or broken wire #36B from end of stroke limit switch LS4 to relay 14CR.
 - Check continuity. Replace if defective.
16. Defective relay 14CR.
 - Check relay. Replace if defective.
17. Loose or broken wire #14A from relay 14CR to relay 28CR.
 - Check continuity. Replace if defective.
18. Loose or broken wire #14B from relay 28CR to base terminal block.
 - Check continuity. Replace if defective.
19. Loose or broken wire #14B from base terminal block to lift valve solenoid 2H-14B.
 - Check continuity. Replace if defective.
20. Loose or broken wire #02 from lift valve solenoid 2H-14B to base terminal block.
 - Check continuity. Replace if defective.
21. Defective lift valve solenoid 2H-14B.
 - Check solenoid. Replace if defective.
13. Open diode D14B-1.
 - Check diode. Replace if defective.

Electrical System (Continued)

4.1-22 Platform will Not Lift from Platform or Base Controls with Outriggers Extended

1. Outriggers not extended enough.
 - [Extend outriggers to take weight off tires \(refer to operator section\).](#)
2. Loose or broken wire #10A from terminal block TB-1 to pin #4 on connector CN14 at the outrigger board.
 - [Check continuity. Replace if defective.](#)
3. Loose or broken wire #10A from outrigger board to outrigger limit switch LS68.
 - [Check continuity. Replace if defective.](#)
4. Defective outrigger limit switch LS68.
 - [Check switch. Replace if defective.](#)
5. Loose or broken wire #68A from outrigger limit switch LS68 to outrigger control module at pin P2-1.
 - [Check continuity. Replace if defective.](#)
6. Loose or broken wire #10A from outrigger board to outrigger limit switch LS67.
 - [Check continuity. Replace if defective.](#)
7. Defective outrigger limit switch LS67.
 - [Check switch. Replace if defective.](#)
8. Loose or broken wire #67A from outrigger limit switch LS67 to outrigger control module at pin P2-2.
 - [Check continuity. Replace if defective.](#)
9. Loose or broken wire #10A from outrigger board to outrigger limit switch LS66.
 - [Check continuity. Replace if defective.](#)
10. Defective outrigger limit switch LS66.
 - [Check switch. Replace if defective.](#)
11. Loose or broken wire #66A from outrigger limit switch LS66 to outrigger control module at pin P2-3.
 - [Check continuity. Replace if defective.](#)
12. Loose or broken wire #10A from outrigger board to outrigger limit switch LS65.
 - [Check continuity. Replace if defective.](#)
13. Defective outrigger limit switch LS65.
 - [Check switch. Replace if defective.](#)
14. Loose or broken wire #65A from outrigger limit switch LS65 to outrigger control module at pin P2-4.
 - [Check continuity. Replace if defective.](#)
15. Check for power on wire #65 at outrigger control module at pin P2-8.
 - [If no voltage present, proceed to outrigger control module troubleshooting.](#)
16. Loose or broken wire #65 from outrigger control module at pin P2-8 to outrigger board CN22 pin #16.
 - [Check continuity. Replace if defective.](#)
17. Defective lift enable relay 65CR.
 - [Check relay. Replace if defective.](#)
18. Defective lift disable relay 17DCR.
 - [Check relay. Replace if defective.](#)
19. Loose or broken wire #36A from pin #10 on connector CN14 at the outrigger board to terminal block TB-1.
 - [Check continuity. Replace if defective.](#)
20. Loose or broken wire #36A from terminal block TB-1 to end of stroke limit switch LS4.
 - [Check continuity. Replace if defective.](#)
21. Defective end of stroke limit switch LS4.
 - [Check switch. Replace if defective.](#)
22. Loose or broken wire #36B from end of stroke limit switch LS4 to relay 14CR.
 - [Check continuity. Replace if defective.](#)
23. Defective relay 14CR.
 - [Check relay. Replace if defective.](#)
24. Loose or broken wire #14A from relay 14CR to relay 28CR.
 - [Check continuity. Replace if defective.](#)

Electrical System (Continued)

25. Loose or broken wire #14B from relay 28CR to base terminal block.
 - Check continuity. Replace if defective.
26. Loose or broken wire #14B from base terminal block to lift valve solenoid 2H-14B.
 - Check continuity. Replace if defective.
27. Loose or broken wire #02 from lift valve solenoid 2H-14B to base terminal block.
 - Check continuity. Replace if defective.
28. Defective lift valve solenoid 2H-14B.
 - Check solenoid. Replace if defective.

4.1-23 Platform will Not Lift from Platform or Base Controls with Outriggers Retracted (lift operates correctly with outriggers extended)

1. Outriggers not fully retracted.
 - Fully retract outrigger cylinders.
2. Loose or broken wire #1 from relay 28CR to pin #7 on connector CN14 at the outrigger board.
 - Check continuity. Replace if defective.
3. Loose or broken wire #1 from outrigger board to outrigger limit switch LS64.
 - Check continuity. Replace if defective.
4. Defective outrigger limit switch LS64.
 - Check switch. Replace if defective.
5. Loose or broken wire #64 from outrigger limit switch LS64 to outrigger board.
 - Check continuity. Replace if defective.
6. Loose or broken wire #64 from outrigger board to outrigger limit switch LS63.
 - Check continuity. Replace if defective.
7. Defective outrigger limit switch LS63.
 - Check continuity. Replace if defective.
8. Loose or broken wire #63 from outrigger limit switch LS63 to outrigger board.
 - Check continuity. Replace if defective.
9. Loose or broken wire #63 from outrigger board to outrigger limit switch LS62.
 - Check continuity. Replace if defective.
10. Defective Limit Switch LS62.
 - Check switch. Replace if defective.
11. Loose or broken wire #62 from outrigger limit switch LS62 to outrigger board.
 - Check continuity. Replace if defective.
12. Loose or broken wire #62 from outrigger board to outrigger limit switch LS61.
 - Check continuity. Replace if defective.
13. Defective outrigger limit switch LS61.
 - Check switch. Replace if defective.
14. Loose or broken wire #61 from outrigger limit switch LS61 to outrigger board .
 - Check continuity. Replace if defective.
15. Open diode D36 on outrigger board.
 - Check diode. Replace if defective.

4.1-24 Up Circuit Inoperative from Base

1. Loose or broken wire #10A from base terminal block to base enable switch S10.
 - Check continuity. Replace if defective.
2. Defective base enable switch S10.
 - Check switch. Replace if defective.
3. Loose or broken wire #10E from base enable switch S10 to base up/down switch S2.
 - Check continuity. Replace if defective.
4. Defective base up/down switch S2.
 - Check switch. Replace if defective.

Electrical System (Continued)

5. Loose or broken wire #14 from base up/down switch S2 to base terminal block TB-1.
 - Check continuity. Replace if defective.

4.1-25 Down Circuit Inoperative from Platform or Base

1. Lift/Off/Drive switch S3 in drive position or defective.
 - Select lift position. Check switch. Replace if defective.
2. Loose or broken wire #09 from lift/off/drive switch S3 to lift enable switch S9.
 - Check continuity. Replace if defective.
3. Defective lift enable switch S9.
 - Check switch. Replace if defective.
4. Loose or broken wire #9A from enable switch S9 to up/down switch S5.
 - Check continuity. Replace if defective.
5. Defective up/down switch S5.
 - Check switch. Replace if defective.
6. Loose or broken wire #13 from up/down switch S5 to relay 13CR. (ANSI/CSA)
 - Check continuity. Replace if defective.
7. Loose or broken wire #13 from up/down switch S5 to diode D13 at base terminal block TB-1. (CE)
 - Check continuity. Replace if defective.
8. Loose or Open diode D13. (CE)
 - Tighten diode. Check diode. Replace if defective.
9. Loose or broken wire #13D to relay 13DCR (CE).
 - Check continuity. Replace if defective.
10. Loose or broken wire #02 from relay 13CR (ANSI/CSA) or 13DCR (CE) to base terminal block TB-1.
 - Check continuity. Replace if defective.
11. Defective relay 13CR (ANSI/CSA) or 13DCR (CE).
 - Check relay. Replace if defective.
12. Loose or broken wire #10A from base terminal block to relay 13CR. (ANSI/CSA only)
 - Check continuity. Replace if defective.
13. Loose or broken wire #13A from relay 13CR (ANSI/CSA) or 13DCR (CE) to base terminal block.
 - Check continuity. Replace if defective.
14. Loose or broken wire #13A from base terminal block to holding valve solenoid 2H-13A-1 or 2H-13A-2 or 2H-13A-3 or 2H-13A-4.
 - Check continuity. Replace if defective.
15. Loose or broken wire #02 from holding valve solenoid 2H-13A-1 or 2H-13A-2 or 2H-13A-3 or 2H-13A-4 to base terminal block TB-1.
 - Check continuity. Replace if defective.
16. Defective holding valve solenoid 2H-13A-1 or 2H-13A-2 or 2H-13A-3 or 2H-13A-4.
 - Check solenoid. Replace if defective.
17. Loose or broken wire #13A from base terminal block to lowering valve solenoid 2H-13A.
 - Check continuity. Replace if defective.
18. Loose or broken wire #02 from lowering valve solenoid 2H-13A to base terminal block.
 - Check continuity. Replace if defective.
19. Defective lowering valve solenoid 2H-13A.
 - Check solenoid. Replace if defective.

4.1-26 Down Circuit Inoperative from Base

1. Loose or broken wire #10A from base terminal block to base enable switch S10.
 - Check continuity. Replace if defective.
2. Defective base enable switch S10.
 - Check switch. Replace if defective.

Electrical System (Continued)

3. Loose or broken wire #10E from base enable switch S10 to base up/down switch S2.
 - Check continuity. Replace if defective.
4. Defective base up/down switch S2.
 - Check switch. Replace if defective.
5. Loose or broken wire #13 from base up/down switch S2 to base terminal block TB-1.
 - Check continuity. Replace if defective.

4.1-27 Powered Extension Platform Inoperative

1. Loose or broken battery cable from main power disconnect switch S1 to fuse F2 (100 Amp).
 - Check continuity. Replace if defective.
2. Open fuse F2.
 - Check fuse. Replace if open.
3. Loose or broken battery cable #103A from fuse F2 to contactor 9CR1.
 - Check continuity. Replace if defective.
4. Defective contactor 9CR1.
 - Check contactor. Replace if defective.
5. Loose or broken battery cable #103B from contactor 9CR1 to motor contactor 99CR.
 - Check continuity. Replace if defective.
6. Defective motor contactor 99CR.
 - Check contactor. Replace if defective.
7. Loose or broken wire #103B from battery cable #103B to fuse F5.
 - Check continuity. Replace if defective.
8. Defective fuse F5.
 - Check fuse. Replace if defective.
9. Loose or broken wire #103C from fuse F5 to powered platform enable switch S34 or S34A.
 - Check continuity. Replace if defective.
10. Loose or broken wire #103D from enable switch S34 or S34A to platform extend retract switch S11 or S11A.
 - Check continuity. Replace if defective.
11. Defective platform extend/retract switch S11 or S11A.
 - Check switch. Replace if defective.
12. Defective platform enable switch S34 or S34A.
 - Check switch. Replace if defective.
13. Loose or broken battery cable #00 from platform power unit DCM1 to battery B1.
 - Check continuity. Replace if defective.
14. Defective platform power unit DCM1.
 - Check power unit. Repair or replace if defective.

4.1-28 Powered Extension Platform will Not Extend

1. Defective platform extend/retract switch S11 or S11A.
 - Check switch. Replace if defective.
2. Loose or broken wire #26 or #26A from platform extend/retract switch S11 or S11A to platform extend valve coil 4H-26 or 4H-26A.
 - Check continuity. Replace if defective.
3. Open diode D26 or D26A.
 - Check diode. Replace if defective.
4. Defective platform extend valve coil 4H-26 or 4H-26A.
 - Check coil. Replace if defective.
5. Loose or broken wire #00 from platform extend valve coil 4H-26 or 4H-26A to battery cable #00.
 - Check continuity. Replace if defective.

Electrical System (Continued)

4.1-29 Powered Extension Platform will Not Retract

1. Defective platform extend/retract switch S11 or S11A.
 - Check switch. Replace if defective.
2. Loose or broken wire #27 or #27A from platform extend/retract switch S11 or S11A to platform retract valve coil 4H-27 or 4H-27A.
 - Check continuity. Replace if defective.
3. Open diode D27 or D27A.
 - Check diode. Replace if defective.
4. Defective platform retract valve coil 4H-27 or 4H-27A.
 - Check coil. Replace if defective.
5. Loose or broken wire #00 from platform retract valve coil 4H-27 or 4H-27A to battery cable #00.
 - Check continuity. Replace if defective.

4.1-30 Hydraulic Generator Inoperative

1. Key switch S3 in drive position.
 - Turn switch to lift position.
2. Loose or broken wire #9 from base terminal block TB-1 to generator relay 86BCR.
 - Check continuity. Replace if defective.
3. Loose or broken wire #9 from generator relay 86BCR to generator switch S12.
 - Check continuity. Replace if defective.
4. Defective generator switch S12.
 - Check switch. Replace if defective.
5. Loose or broken wire #85 from generator switch S12 to generator relay 86ACR.
 - Check continuity. Replace if defective.
6. Loose or broken wire #85 from generator relay 86ACR to generator relay 86BCR.
 - Check continuity. Replace if defective.
7. Loose or broken wire #86B from generator relay 86ACR to generator relay 86BCR.
 - Check continuity. Replace if defective.
8. Defective relay 86ACR.
 - Check relay. Replace if defective.
9. Defective relay 86BCR.
 - Check relay. Replace if defective.
10. Open diode D86C-1.
 - Check diode. Replace if defective.
11. Loose or broken wire #17 from diodes D86B-1 to relay 17CR.
 - Check continuity. Replace if defective.
12. Loose or broken wire #2A from relays 10ACR2 and 86BCR to relay 10ACR1.
 - Check continuity. Replace if defective.
13. Loose or broken wire #85A from circuit breaker CB4 to relay 86BCR.
 - Check continuity. Replace if defective.
14. Tripped or defective circuit breaker CB4.
 - Reset circuit breaker. Replace if defective.
15. Loose or broken wire #3 from circuit breaker CB4 to circuit breaker CB1.
 - Check continuity. Replace if defective.
16. Loose or broken wire #86C from relay 86BCR to generator valve coil 2H-86C.
 - Check continuity. Replace if defective.
17. Loose or broken wire #02 from base terminal block to generator valve coil 2H-86C.
 - Check continuity. Replace if defective.
18. Defective generator valve coil 2H-86C.
 - Check coil. Replace if defective.

Electrical System (Continued)

4.1-31 Hydraulic Generator will Not Shut Off from Generator Switch

1. Defective generator switch S12.
 - Check switch. Replace if defective.
2. Loose or broken wire #86 from generator switch S12 to diode D86.
 - Check continuity. Replace if defective.
3. Open diode D86.
 - Check diode. Replace if defective.
4. Defective relay 86ACR.
 - Check relay. Replace if defective.
5. Loose or broken wire #02 from base terminal block to relay 86ACR.
 - Check continuity. Replace if defective.

4.1-32 All Outriggers Inoperative (Auto-level and manual)



WARNING

Scissors lift must be below high speed limit switch for outriggers to function.

NOTE

For the outriggers to function the upper control console must be in the lift position.

1. No power on wire #44 at relay 35CR.
 - If no power is present ensure there is power on wire #35 and relay 35CR operates correctly.
2. Loose or broken wire #44 from relay 35CR to pin #6 on connector CN14 on outrigger board.
 - Check for continuity. Replace if defective.
3. No power at wire #9 at pin #5 on connector CN14 on outrigger board.
 - If no power is present check for continuity on wire #9 back to base terminal block TB-1. Replace if defective.
4. Defective relay 9CR2 or 9CR3 on outrigger board.
 - Check relays. Replace if defective.
5. Defective relay 17DCR on outrigger board.
 - Check relay. Replace if defective.
6. Open or broken jumper J17E on outrigger board.
 - Check jumper. Replace if defective.
7. Open diode D17B-1 on outrigger board.
 - Check diode. Replace if defective.
8. Loose or broken wire #17 from pin #2 on connector CN14 on outrigger board to relay 35CR or relay 17CR.
 - Check for continuity. Replace if defective.
9. Loose or broken wire #17B from pin #1 or wire #02 from pin #2 on connector CN21 on outrigger board to outrigger holding valve coil 2H-17B.
 - Check for continuity. Replace if defective.
10. Defective outrigger holding valve coil 2H-17B.
 - Check coil. Replace if defective.

4.1-33 All Outriggers Inoperative (Auto-level and manual from platform controls)

1. Loose or broken wire #35C from pin #1 on connector CN20 on outrigger board through outrigger cables and plugs to the outrigger enable switch S9A in the control console.
 - Check for continuity. Replace if defective.

Electrical System (Continued)

2. Loose or broken wire #35D from outrigger enable switch S9A to pin #5 on the outrigger control console plug.
 - Check for continuity. Replace if defective.
3. Defective outrigger enable switch S9A.
 - Check switch. Replace if defective.

4.1-34 All Outriggers Inoperative (Base Controls)

1. Defective outrigger enable switch S9B.
 - Check switch. Replace if defective.

4.1-35 All Outriggers Inoperative (Auto-level)

A: Led Power Indicator Light at Outrigger Control Module (OCM1) Not on Constant

1. Loose or broken wire #10A from pin #1 of the tilt switch connector to pin P2-12 on the outrigger control module OCM1.
 - Check for continuity. Replace if defective.
2. Loose or broken wire #10A from pin #1 of the tilt switch connector to main terminal block TB-1.
 - Check for continuity. Replace if defective.
3. Loose or broken wire #02 from pin #3 of the tilt switch connector to pin P2-11 on the outrigger control module OCM1.
 - Check for continuity. Replace if defective.
4. Loose or broken wire #02 from pin #3 of the tilt switch connector to main terminal block TB-1.
 - Check for continuity. Replace if defective.
5. Defective outrigger control module OCM1.
 - Replace.
 -

Electrical System (Continued)

4.1-36 All Outriggers Inoperative (Auto Level)

B: Led Power Indicator Light at Outrigger Control Module (OCM1) Flashing

Flash Code	Probable Cause	Remedy
1/1	1. Outriggers are all up and machine is tilted.	1. Level the machine.
1/2	1. Machine is elevated. 2. Loose or broken wire # 35.	1. Lower the scissor stack below high speed limit switch. 2. Check for input voltage on wire #35 at pin P2-10 of the outrigger control module (OCM1). Replace if defective.
2/2	1. At least one outrigger is not fully retracted. 2. Defective outrigger rod limit switch (LS61, LS62, LS63, LS64) or wiring. 3. Defective diode (D36) on outrigger board.	1. Fully retract all outriggers. 2. Replace defective or damaged switch(es) or wiring. 3. Check for continuity. Replace if defective.
2/1	1. Outriggers are all down and the machine is not fully level.	1. Move machine to less sloped terrain if it will not lift.
5/5	1. Power on wire #70 or #79 at power on. 2. Power on wire #70 or #79 when manually operating outriggers.	1. Check for power on wire #70 or #79 at pin P2-5 or P2-6 of the outrigger control module. Replace defective component. 2. Check for power on wire #70 or #79 while manually operating an outrigger.
5/2	1. Low or no voltage on wire #35c. 2. Loose or broken wire on #35c.	1. Check battery and charging system to ensure minimum 9 volts. 2. Check for input voltage on wire #35c at pin P4-9 of outrigger control module (OCM1).
7/1	1. Excessive vibration. 2. Defective outrigger control module.	1. Outrigger control module cannot read tilt sensor. 2. Replace.
6/6	1. Outriggers are being manually controlled.	1. Indicates function activated. No repair necessary.
7/8	1. Error occurred while self diagnosing the hardware fail safe.	1. Turn off power to reset the outrigger control module. Turn power back on and see if the code has cleared. If problem persists, replace outrigger control module.
5/1	1. Low input voltage to outrigger control module.	1. Check for minimum 9 volts between wire #02 at pin P2-11 and wire #10A at pin P2-12 at outrigger control module.
7/7	1. Startup error occurred while self diagnosing.	1. Turn off power to reset the outrigger control module. Turn power back on and see if the code has cleared. If problem persists, replace outrigger control module.
7/5	1. Internal failure of OCM1.	1. Turn off power to reset the outrigger control module. Turn power back on and see if the code has cleared. If problem persists, replace outrigger control module.
7/2	1. Internal failure of OCM1.	1. Turn off power to reset the outrigger control module. Turn power back on and see if the code has cleared. If problem persists, replace outrigger control module.
8/1	1. Internal failure of OCM1.	1. Turn off power to reset the outrigger control module. Turn power back on and see if the code has cleared. If problem persists, replace outrigger control module.
8/2	1. Internal failure of OCM1.	1. Turn off power to reset the outrigger control module. Turn power back on and see if the code has cleared. If problem persists, replace outrigger control module.
8/3	1. Internal failure of OCM1.	1. Turn off power to reset the outrigger control module. Turn power back on and see if the code has cleared. If problem persists, replace outrigger control module.
8/4	1. Internal failure of OCM1.	1. Turn off power to reset the outrigger control module. Turn power back on and see if the code has cleared. If problem persists, replace outrigger control module.
8/5	1. Internal failure of OCM1.	1. Turn off power to reset the outrigger control module. Turn power back on and see if the code has cleared. If problem persists, replace outrigger control module.
7/6	1. Internal failure of OCM1.	1. Turn off power to reset the outrigger control module. Turn power back on and see if the code has cleared. If problem persists, replace outrigger control module.

60416AA

Electrical System (Continued)

4.1-37 Left Front Outrigger Inoperative Manually

1. Defective left front outrigger switch S20 at platform, or S20A at base.
 - Check switch. Replace if defective.
2. Loose or broken wire #71 from outrigger control console to pin #6 on connector CN20 at outrigger board (retract), or from wire #75 to pin #7 (extend).
 - Check continuity. Replace if defective.
3. Open diode D71 (retract) or D75 (extend) on outrigger board.
 - Check diode. Replace if defective.
4. Loose or broken wire #71 from pin #7 on connector CN21 at outrigger board to valve coil 4H-71 (retract), or wire #75 from pin #8 to 4H-75 (extend).
 - Check continuity. Replace if defective.
5. Loose or broken wire #02 from valve coil 4H-71 (retract) or 4H-75 (extend) to pin #2 on connector CN21 at the outrigger board.
 - Check continuity. Replace if defective.

4.1-38 Right Front Outrigger Inoperative Manually

1. Defective right front outrigger switch S21 at platform, or S21A at base.
 - Check switch. Replace if defective.
2. Loose or broken wire #72 from outrigger control console to pin #8 on connector CN20 at outrigger board (retract), or from wire #76 to pin #9 (extend).
 - Check continuity. Replace if defective.
3. Open diode D72 (retract) or D76 (extend) on outrigger board.
 - Check diode. Replace if defective.
4. Loose or broken wire #72 from pin #9 on connector CN21 at outrigger board to valve coil 4H-72 (retract), or wire #76 from pin #10 to 4H-76 (extend).
 - Check continuity. Replace if defective.
5. Loose or broken wire #02 from valve coil 4H-72 (retract) or 4H-76 (extend) to pin #2 on connector CN21 at the outrigger board.
 - Check continuity. Replace if defective.

4.1-39 Right Rear Outriggers Inoperative Manually

1. Defective right rear outrigger switch S22 at platform, or S22A at base.
 - Check switch. Replace if defective.
2. Loose or broken wire #73 from outrigger control console to pin #3 on connector CN20 at outrigger board (retract), or from wire #77 to pin #4 (extend).
 - Check continuity. Replace if defective.
3. Open diode D73 (retract) or D77 (extend) on outrigger board.
 - Check diode. Replace if defective.
4. Loose or broken wire #73 from pin #4 on connector CN21 at outrigger board to valve coil 4H-73 (retract), or wire #77 from pin #4 to 4H-77 (extend).
 - Check continuity. Replace if defective.
5. Loose or broken wire #02 from valve coil 4H-73 (retract) or 4H-77 (extend) to pin #2 on connector CN21 at the outrigger board.
 - Check continuity. Replace if defective.

4.1-40 Left Rear Outriggers Inoperative Manually

1. Defective left rear outrigger switch S23 at platform, or S23A at base.
 - Check switch. Replace if defective.
2. Loose or broken wire #74 from outrigger control console to pin #5 on connector CN20 at outrigger board (retract), or from wire #78 to pin #2 (extend).
 - Check continuity. Replace if defective.

Electrical System (Continued)

3. Open diode D74 (retract) or D78 (extend) on outrigger board.
 - Check diode. Replace if defective.
4. Loose or broken wire #74 from pin #6 on connector CN21 at outrigger board to valve coil 4H-74 (retract), or wire #78 from pin #3 to 4H-78 (extend).
 - Check continuity. Replace if defective.
5. Loose or broken wire #02 from valve coil 4H-74 (retract) or 4H-78 (extend) to pin #2 on connector CN21 at the outrigger board.
 - Check continuity. Replace if defective.

4.1-41 Individual Outrigger Functions Inoperative (Auto-level)

1. Loose or broken wire #71- #75 (depending on function not working) at pins 1-8 of outrigger control module plug P4.
 - Check connections of outrigger functions not working (refer to Section 5 for pin reference chart). Replace if defective.
2. No output from outrigger control module OCM1 at pins 1-8 of outrigger control module plug P4.
 - Turn off power to reset the outrigger control module. Turn power back on and retest. If problem persists, replace outrigger control module.

4.1-42 Auto-level Inoperative

1. Loose or broken wire #35D from outrigger enable switch S9A to auto mode outrigger switch S24.
 - Check continuity. Replace if defective.
2. Defective auto mode outrigger switch S24.
 - Check switch. Replace if defective.
3. Loose or broken wire #10A at pin #P2-12 on outrigger control module OCM1.
 - Check for power at P2-12. If no voltage present, check continuity of wire. Replace if defective.
4. Loose or broken wire #35 at pin #P2-10 on outrigger control module OCM1.
 - Check for power at P2-10. If no voltage present, check continuity of wire. Replace if defective.
5. Loose or broken wire #02 at pin #P2-11 on outrigger control module OCM1.
 - Check for ground at P2-11. If no ground present, check continuity of wire. Replace if defective.
6. Loose or broken wire #70 from auto mode outrigger switch S24 to pin #P2-5 on outrigger control module OCM1.
 - Check continuity. Replace if defective.

4.1-43 Auto All Up Inoperative (Retract)

1. Loose or broken wire #35D from outrigger enable switch S9A to auto mode outrigger switch S24.
 - Check continuity. Replace if defective.
2. Defective auto mode outrigger switch S24.
 - Check switch. Replace if defective.
3. Loose or broken wire #10A at pin #P2-12 on outrigger control module OCM1.
 - Check for power at P2-12. If no voltage present, check continuity of wire. Replace if defective.
4. Loose or broken wire #35 at pin #P2-12 on outrigger control module OCM1.
 - Check for power at P2-10. If no voltage present, check continuity of wire. Replace if defective.
5. Loose or broken wire #02 at pin #P2-11 on outrigger control module OCM1.
 - Check for ground at P2-11. If no ground present, check continuity of wire. Replace if defective.
6. Loose or broken wire #70 from auto mode outrigger switch S24 to pin #P2-5 on outrigger control module OCM1.
 - Check continuity. Replace if defective.

Hydraulic System

4.2-1 All Functions Inoperative

1. Hydraulic oil level low.
 - Refill tank to proper level.
2. Defective pump P1.
 - Check pump. Repair or replace if defective.
3. Broken engine to pump coupler.
 - Check coupler. Replace if defective.
4. Open relief valve R1.
 - Check valve. Replace if defective.

4.2-2 Steering Inoperative

1. Stuck or defective brake feed valve 2H-30A-2.
 - Check valve. Repair or replace if defective.
2. Stuck or defective steer right valve 4H-23A or steer left valve 4H-24A.
 - Check valves. Replace if defective.
3. Steer cylinder C7 damaged or bypassing internally.
 - Check cylinder. Repair or replace if defective.

4.2-3 Steer and First Drive Speed Inoperative

1. Small pump dump valve 2H-18A stuck open.
 - Check valve. Repair or replace if defective.
2. Worn or defective small pump section of pump P1.
 - Check pump. Repair or replace if defective.
3. Check valve CV1 or CV2 stuck.
 - Check valves. Clean or replace if defective.

4.2-4 Lift and Second Drive Speed Inoperative

1. Large pump dump valve 2H-17A stuck open.
 - Check valve. Repair or replace if defective.
2. Worn or defective large pump section of pump P1.
 - Check pump. Repair or replace if defective.
3. Check valve CV1 or CV2 stuck.
 - Check valves. Clean or replace if defective.

4.2-5 Drive Inoperative

1. Stuck or defective drive reverse valve 4H-15B or drive forward valve 4H-16B.
 - Check valves. Repair or replace if defective.
2. Defective motion control valve MC1.
 - Check valve. Repair or replace if defective.
3. Missing or defective check balls in series/parallel valve manifold 3H-20A.
 - Repair or replace balls. Refer to Section 5 for proper location.
4. Stuck or defective main series/parallel valve spool V3 in drive motor.
 - Check valve. Repair or replace if defective.
5. Defective drive motor M1.
 - Check motor. Repair or replace if defective.
6. Free wheeling valve 2H-30A stuck.
 - Check valve. Repair or replace if defective.
7. Cushion cylinder C8 bypassing internally.
 - Check cylinder. Repair or replace if defective.

Hydraulic System (Continued)

4.2-6 Reverse Drive Inoperative

1. Stuck or defective drive valve 4H-15B.
 - Check valve. Repair or replace if defective.
2. Stuck or defective check valve in motion control assembly MC1.
 - Check valves. Clean or replace if defective.

4.2-7 Forward Drive Inoperative

1. Stuck or defective drive valve 4H-16B.
 - Check valve. Repair or replace if defective.
2. Stuck or defective check valve in motion control assembly MC1.
 - Check valves. Clean or replace if defective.

4.2-8 Brakes will Not Release

1. Stuck or defective brake feed valve 2H-30A-2.
 - Check valve. Repair or replace if defective.
2. Stuck or defective brake dump valve 2H-30A-1.
 - Check valve. Repair or replace if defective.
3. Stuck or defective brake valve 2H-25. (If equipped)
 - Check valve. Repair or replace if defective.
4. Stuck or defective auto reset valve V6. (If equipped)
 - Check valve. Repair or replace if defective.
5. Defective disc brake pack BP1. (Internal brake)
 - Check brake pack. Repair or replace if defective.
6. Defective brake cylinder C5 or C6. (External brake cylinders)
 - Check cylinder. Repair or replace if defective.

4.2-9 Brakes will Not Release (Internal Brake)

1. Bad o-rings internal to brake. (If release piston will not hold pressure, brake will not release.)
 - Check for hydraulic oil in axle. Replace o-rings if defective.
2. Discs frozen. (These brakes are designed for only limited dynamic braking. A severe emergency stop or prolonged reduced release pressure operation may result in this type of damage.)
 - Check for abnormal wear. Replace disc stack if defective.

4.2-10 Brake Slips (Internal Brake)

1. Excessive pressure in hydraulic system. (If there is back pressure in the actuation line of the brake, holding torque will be reduced)
 - Check filters, hose size, restrictions in other hydraulic components.
2. Oil in brake if designed for dry use. (Wet linings generate 67% of the dry torque rating. If the brake has oil in it, check the type of oil hydraulic or gearbox. i. Gearbox oil ii. Hydraulic oil)
 - Replace oil seal in brake. Check motor seal. Check piston seals.

NOTE

Internal components will need to be inspected, cleaned and replaced as required.

3. Disc plates worn. (The thickness of the disc stack sets the torque level. A thin stack reduces torque.)
 - Check brake's holding torque is sufficient.
 - i) Make sure the machine is parked on level ground.
 - ii) Locate the brake feed valve (2H30A-2) on the main manifold. Disconnect the electrical connectors from this valve. This will prevent the hydraulic system from releasing the brake.

Hydraulic System (Continued)

- iii) With the engine running, machine in drive mode, engine on high idle, high torque selected and low speed range selected, hold the enable switch on the joystick and push the joystick forward as if you were to drive forward. This provides torque from the drive motor to the unreleased brake.
- v) If the brake slips and the machine starts to move in this condition, either the brake plates are worn or the springs have broken. Both the springs and the brake plates must be replaced to return the brake to its original holding torque.

4.2-11 Brake Drags or Runs Hot (Internal Brake)

1. Low brake pressure.
 - Place pressure gauge in brake line. Brakes use system pressure. (Minimum 335 psi required)
2. Bearing failure (If the bearing should fail, a large amount of drag can be generated)
 - Replace bearing

4.2-12 Up Circuit Inoperative

1. Stuck or defective lift valve 2H-14B.
 - Check valve. Repair or replace if defective.
2. Stuck check valve CV3.
 - Check valve. Replace if defective.
3. Misadjusted or defective lift relief valve R2.
 - Adjust valve. Replace if defective.
4. Stuck or defective lowering valve 2H-13A.
 - Check valve. Repair or replace if defective.
5. Stuck or defective manual lowering valve V1.
 - Check valve. Repair or replace if defective.
6. Open or defective brake feed valve 2H-30A-2.
 - Check valve. Repair or replace if defective.
7. Open manual override on holding valve 2H-13A-1 or 2H-13A-2 or 2H-13A-3 or 2H-13A-4.
 - Depress and turn manual override clockwise to close. Replace if defective.
8. Stuck holding valve 2H13A-1 or 2H13A-2 or 2H-13A-3 or 2H-13A-4.
 - Check valves. Repair or replace if defective.

4.2-13 Down Circuit Inoperative

1. Stuck or defective lowering valve 2H-13A.
 - Check valve. Repair or replace if defective.
2. Stuck holding valve 2H13A-1 or 2H13A-2 or 2H-13A-3 or 2H-13A-4.
 - Check valves. Repair or replace if defective.
3. Plugged lowering orifice O1.
 - Clean or replace orifice.

4.2-14 Powered Extension Platform Inoperative

1. Defective powered extension pump P3.
 - Check pump. Repair or replace if defective.
2. Misadjusted or defective relief valve R5.
 - Adjust valve. Replace if defective.
3. Stuck or defective deck extend valve 4H-26 or 4H-26A or retract valve 4H-27 or 4H-27A.
 - Check valves. Repair or replace if defective.
4. Defective powered extension cylinder C13 front or C14 rear.
 - Check cylinder. Repair or replace if defective.

4.2-15 Hydraulic Generator Inoperative

Hydraulic System (Continued)

1. Stuck or defective hydraulic generator valve 2H-86C.
 - Check valve. Repair or replace if defective.
2. Misadjusted or defective flow control valve FC1.
 - Adjust valve. Replace if defective.
3. Stuck or defective large pump dump valve 2H-17A.
 - Check valve. Repair or replace if defective.
4. Defective hydraulic generator hydraulic motor GM1.
 - Check motor. Repair or replace if defective.

4.2-16 All Outriggers Inoperative

1. Stuck or defective outrigger holding valve 2H-17B.
 - Check valve. Repair or replace if defective.

4.2-17 Left Front Outrigger Inoperative

1. Stuck or defective retract valve 4H-71 or extend valve 4H-75.
 - Clean valve. Replace if defective.
2. Stuck or defective check valve CV5.
 - Check valve. Replace if defective.
3. Bypassing outrigger cylinder C9.
 - Repack cylinder. Replace if defective.

4.2-18 Right Front Outrigger Inoperative

1. Stuck or defective retract valve 4H-72 or extend valve 4H-76.
 - Clean valve. Replace if defective.
2. Stuck or defective Check valve CV6.
 - Check valve. Replace if defective.
3. Bypassing outrigger cylinder C10.
 - Repack cylinder. Replace if defective

4.2-19 Right Rear Outrigger Inoperative

1. Stuck or defective retract valve 4H-73 or extend valve 4H-77.
 - Clean valve. Replace if defective.
2. Stuck or defective check valve CV7.
 - Check valve. Replace if defective.
3. Bypassing outrigger cylinder C11.
 - Repack cylinder. Replace if defective

4.2-20 Left Rear Outrigger Inoperative

1. Stuck or defective retract valve 4H-74 or extend valve 4H-78.
 - Clean valve. Replace if defective.
2. Stuck or defective check valve CV4.
 - Check valve. Replace if defective.
3. Bypassing outrigger cylinder C12.
 - Repack cylinder. Replace if defective

4.2-21 Outriggers Drift In

1. Defective check valve left front (CV4), right front (CV5), right rear (CV6) or left rear (CV7)
 - Clean valve. Replace if defective.
2. Outriggers cylinder bypassing left front (C9), right front (C10), right rear (C11) or left rear (C12).
 - Repack cylinder. Replace if defective

Section 5 PROCEDURES

Table of Contents

General	106
Safety and Workmanship.....	106
Base	
5.1-1 Hydraulic System and Brake Adjustment Procedure (If Equipped)	106
5.1-2 Brake Assembly and Disassembly (If Equipped).....	107
5.1-3 Holding Torque Testing Procedure.....	109
5.1-4 Winching and Towing Procedures and Brake System.....	109
5.1-5 System Lift and Pressure Adjustment	110
5.1-6 Change Hydraulic Oil.....	111
5.1-7 Wheel Bolt/Nut Inspection and Torquing Procedure.....	111
5.1-8 Wheel Reinstallation and Torquing Procedure.....	112
5.1-9 Front Axle Hub Procedure	112
Outriggers	
5.2-1 Auto-Leveling Outrigger PC Board Layout.....	114
5.2-2 Outrigger Mechanical Limit Switch Wiring Diagram	115
5.2-3 Auto-Leveling Outrigger Setting and Error Codes	116
5.2-4 Auto-Leveling Outrigger Error Code Breakdown	117
5.2-5 Hand Held Calibration/Diagnostic Tool Key Functions	118
5.2-6 Outrigger Control Module Instructions.....	119
5.2-7 Auto-Leveling Outrigger Control Module Pin Reference Chart.....	122
5.2-8 Outrigger Upper Limit Switch (LS61, LS62, LS63, LS64) Replacement and Adjustment	123
5.2-9 Outrigger Lower Limit Switch (LS65, LS66, LS67, LS68) Replacement and Adjustment	124
Scissors	
5.3-1 End of Stroke Limit Switch (LS4) Replacement and Adjustment.....	126
5.3-2 High Speed Cutout (LS5) and Lift Cutout (LS1) Limit Switch Replacement and Adjustment.....	128
Platform	
5.4-1 Gate Spring Hinge Adjustment.....	130



General

The following information is provided to assist you in the use and application of servicing and maintenance procedures contained in this chapter.

Safety and Workmanship

Your safety, and that of others, is the first consideration when engaging in the maintenance of equipment. Always be conscious of weight. Never attempt to move heavy parts without the aid of a mechanical device. Do not allow heavy objects to rest in an unstable position. When raising a portion of the equipment, ensure that adequate support is provided.

Base**5.1-1 Hydraulic System and Brake Adjustment Procedure (If Equipped)**

1. Ensure aerial platform is on a firm level surface and block wheels to prevent rolling in either direction.
2. Turn emergency main power disconnect switch to OFF position.
3. Locate brake manifold in hydraulic/electric side cabinet.
4. Depress and turn red knurled knob on brake valve counter-clockwise to a fully closed position or depress black knob (current manifold).
5. Grasp red plunger and rapidly depress until plunger can no longer be depressed and brake is fully released.
6. Inspect caliper and brake pads for binding. Pads should move freely on the pins.
7. Remove pin from brake cylinder clevis and brake actuating lever. Rotate actuating lever counter-clockwise to the end of its stroke.

HOLD ACTUATOR ARM
TO FULL COUNTER-CLOCKWISE

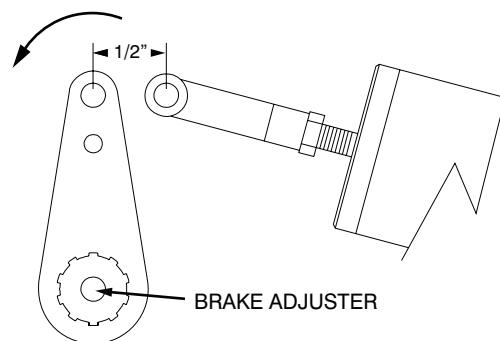

Diagram 5.1 Brake Adjustment

9. Reinstall clevis pin back into the clevis actuating lever.
10. Remove plastic plug located on the end of the caliper shaft. See [Diagram 5.2](#).

HOLD ACTUATOR ARM
TO FULL COUNTER-CLOCKWISE

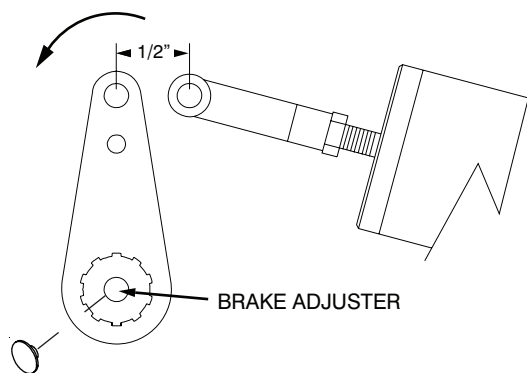

Diagram 5.2 Plug Removal and Replacement

11. Using a 1/4" Allen wrench, turn brake adjuster counter-clockwise until it bottoms out. Turn Allen wrench clockwise 1/2 turn clockwise to set adjustment.
12. Replace plastic plug back into the end of the caliper shaft.
13. Depress red knurled knob on brake valve and turn clockwise to a fully open position.
14. Remove Wheel blocks. Turn emergency main power disconnect switch to ON position. Operate drive several times to seat pads to brake disc.

5.1-2 Brake Assembly and Disassembly (If Equipped)

NOTE

This literature services various models in this brake series. The components shown in [Diagram 5.3](#) may appear different than what is found in your brake.

Disassembly (Refer to [Diagram 5.3](#))

1. Remove pressure plate from cover by removing cap screws.



CAUTION

Pressure plate is under spring tension of approximately 1633 kgf (3600 lb). The two cap screws must be loosened evenly to relieve this force. If a hydraulic press is available, 2041 kgf (4500 lb) minimum, the pressure plate can be held in position while removing the cap screws.

2. Remove case seal from cover.
3. Remove piston from pressure plate.
4. Remove o-rings and back-up rings from piston.
5. Before removing stator discs and rotor discs, record the stacking arrangement for reassembly purposes. Remove stator discs, rotor discs, return plate and shaft from cover.
6. Before removing springs, record the pattern and color for reassembly purposes. Remove dowel pins, springs and spring retainer from cover.
7. Press oil seal from cover.

Spring Chart			
Model	Yellow Spring (14)	Red Spring (14)	Blue Spring (14)
21-100-114	16	0	0

Assembly (Refer to [Diagram 5.3](#))

1. Use an alkaline wash to clean parts before assembly.
2. Press new oil seal into cover until it is flush with bearing shoulder. Note direction of seal.
3. Install shaft, dowel pins, spring retainer and new spring in cover. Be sure to install springs according to pattern and color recorded during disassembly.
4. Position new return plate on springs.

NOTE

Be careful to avoid contaminating friction surfaces with oil.

5. Install new rotor discs and new stator discs in the same sequence as recorded during disassembly.
6. Install new back-up rings and new o-rings on piston. Note order of o-rings and back-up rings. Insert piston into pressure plate.
7. Install new case seal on cover.
8. Position pressure plate on cover aligning dowel pins with holes in pressure plate.
9. Install cap screws and tighten evenly to draw pressure plate to cover. Torque cap screws 74.6 N-m (55 lb-ft).

NOTE

A hydraulic press will simplify installation of pressure plate on cover. Clamp pressure plate in position while tightening cap screws.



CAUTION

If hydrostatic testing is performed on brake assembly, release pressure must not exceed 69 bar (1000 psi) unless six additional bolts are used for supplemental clamping.

Diagram 5.3 Multiple Disc Brake Assembly

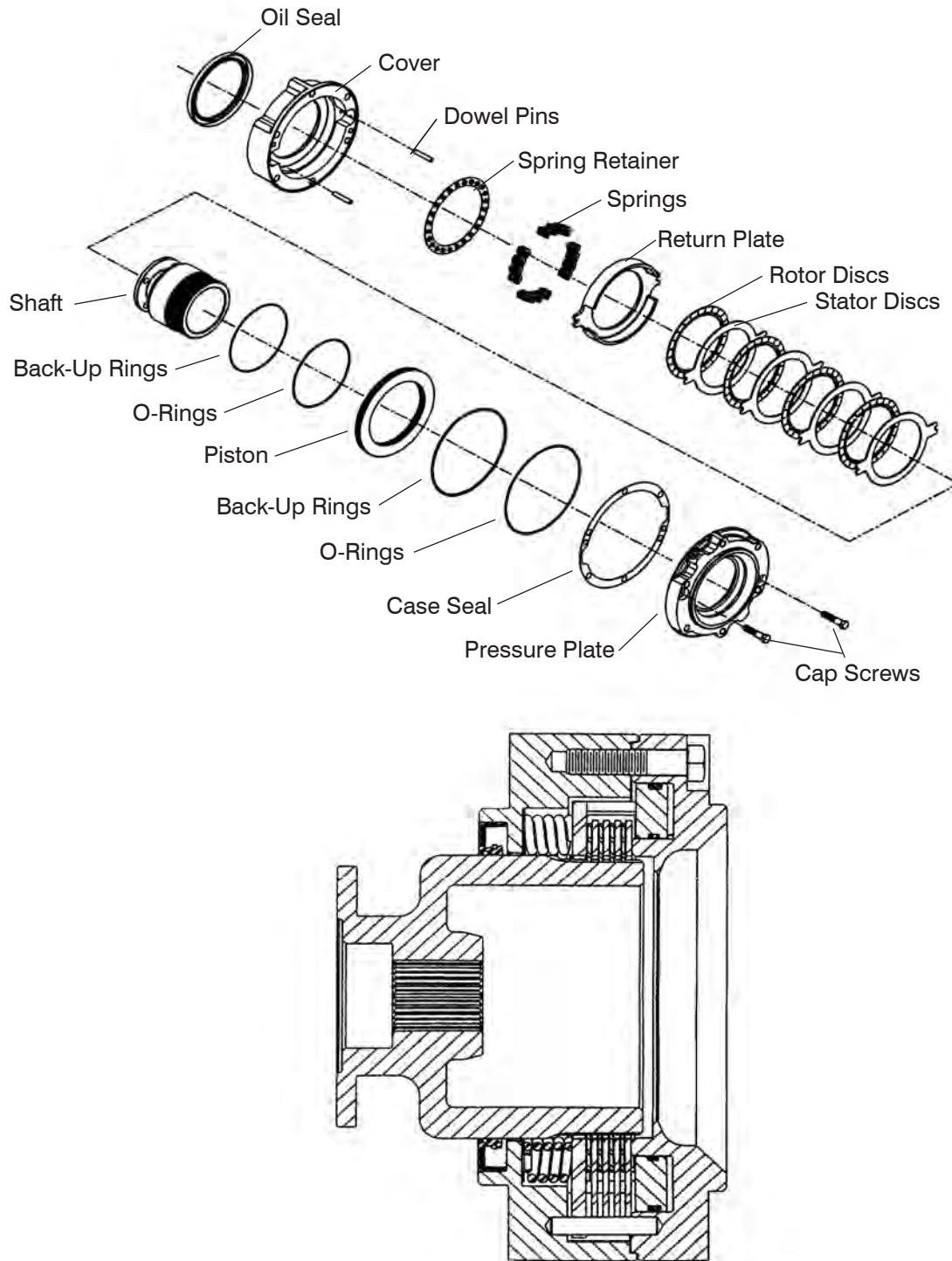

M11512AA

5.1-3 Holding Torque Testing Procedure

1. Ensure aerial platform is on a firm level surface.
2. Locate brake feed valve (2H30A-2) on main manifold and disconnect electrical connectors from valve. This will prevent the hydraulic system from releasing the brake.
3. With engine running (aerial platform in drive mode, engine on high idle, high torque selected and low speed range selected), hold enable switch on controller and push controller forward as if you were to drive forward. This provides torque from the drive motor to unreleased brake.
4. If brake slips and aerial platform starts to move in this condition, either brake plates are worn or springs have broken. Both brake plates and springs must be replaced to return brake to its original holding torque.

5.1-4 Winching and Towing Procedures and Brake System**WARNING**

When towing, do not drive onto a downward slope or brake the towing vehicle rapidly.

Disc Brake System

Diagram 5.4 Disc Brake System

Disc Brake -This device disengages the brake disc (1) when driving forward or in reverse. A hydraulic brake cylinder (2), linked to a disc caliper (3), engages and disengages a brake disc on the rear axle drive shaft yoke. The brake must be manually disengaged for pushing, towing or winching. Do not push or tow the work platform onto a downward slope or pull the platform down an incline towards the winch. The special procedure for manually disengaging the parking brake is as follows:

**WARNING**

Do not manually disengage parking brakes if work platform is on a slope.

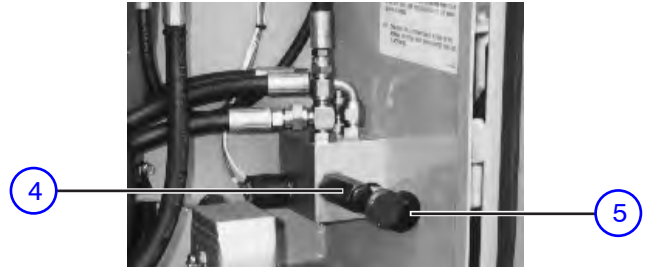

Diagram 5.5 Brake Release Hand Pump and Brake Valve Plunger

1. Ensure aerial platform is on a firm level surface.
2. Locate brake feed valve (2H30A-2) on main manifold and disconnect electrical connectors from valve. This will prevent the hydraulic system from releasing the brake.
3. With engine running (aerial platform in drive mode, engine on high idle, high torque selected and low speed range selected), hold enable switch on controller and push controller forward as if you were to drive forward. This provides torque from drive motor to unreleased brake.
4. If brake slips and aerial platform starts to move in this condition, either brake plates are worn or springs have broken. Both brake plates and springs must be replaced to return brake to its original holding torque.

5.1-5 System Lift and Pressure Adjustment

All adjustments must be made with a calibrated hydraulic gauge. Refer to the serial number nameplate located on the rear of the aerial platform for system and lift pressure values.

System Relief Pressure Adjustment

1. Locate right steer hydraulic line on main manifold. (Refer to Hydraulic Manifold Component and Port Identification found in [section 3](#) for location.)
2. Tee in a calibrated 3000 psi gauge into the right steer line.
3. Remove operator's control console from guardrail and disconnect it from scissors control cable.
4. Locate electrical panel cable plug in hydraulic/electric cabinet.
5. Disconnect scissors control cable and connect operator's control console cable.
6. At main manifold, loosen locknut on system relief valve (R1). (Refer to Hydraulic Manifold Component and Port Identification found in [section 3](#) for location.)
7. On platform control console, select "drive" position with lift/drive switch.
8. Engage right steer switch on top of controller handle and hold.
9. Observe reading on pressure gauge. Adjust system relief valve (R1) to pressure listed on the serial number nameplate.

NOTE

Turning the stem on relief valve clockwise will increase pressure. Turning the stem counter-clockwise will decrease pressure.

10. Release steer switch and retighten locknut on system relief valve (R1).
11. Remove gauge from steer line.

Lift Pressure Adjustment**WARNING**

Fully lower the platform.

1. Locate lift line on main manifold. (Refer to Hydraulic Manifold Component and Port Identification found in [section 3](#) for location.)
2. Open manual lowering valve with platform fully lowered. Remove lift line from main manifold.
3. Install a 3000 psi gauge into lift line port fitting on main manifold. Plug lift line going to lift cylinders.
4. Loosen locknut on lift relief valve (R2). (Refer to Hydraulic Manifold Component and Port Identification found in [section 3](#) for location.)
5. Close the manual lowering valve.
6. Using base controls in hydraulic/electric cabinet, depress and hold up pushbutton switch.
7. Observe reading on pressure gauge. Adjust lift relief valve (R2) to pressure listed on the serial number nameplate.

NOTE

Turning the stem on relief valve clockwise will increase pressure. Turning the stem counter-clockwise will decrease pressure.

8. Release up pushbutton and retighten locknut on lift relief valve (R2).
9. Remove gauge from lift line port fitting and reconnect lift line to main manifold.

**WARNING**

Ensure aerial platform does not lift more than rated load.

5.1-6 Change Hydraulic Oil**NOTE**

Samples of hydraulic oil should be drawn from the reservoir and tested annually. These samples should be taken when the oil is warmed through normal operation of the system. The sample should be analyzed by a qualified lubrication specialist to determine if it is suitable for continued use. Oil change intervals will depend on the care used in keeping the oil clean, and the operating conditions. Dirt and/or moisture contamination will dictate that the oil should be changed more often. Under normal use and operating conditions, the hydraulic oil should be changed every two years. Refer to [Table 1.2](#) of this manual.

1. Ensure aerial platform is on a firm level surface, fully lowered, and outriggers (if equipped) fully retracted.
2. Allow hydraulic oil to warm up.
3. Turn main power disconnect switch to off position.
4. Place suitable container under the hydraulic tank.
5. Remove oil drain plug and allow all hydraulic oil to drain into container.
6. Install oil drain plug with new seal ring and tighten firmly.
7. Refill hydraulic tank with new oil as per specifications. (Refer to [section 2](#) of this manual)
8. Check for leakage.
9. Clean up any oil that may have spilled during this procedure.
10. Check hydraulic oil level. (The hydraulic oil level should be at or slightly above the top mark on the sight gauge)

NOTE

Refer to your national/local regulations on how to dispose of used filter and oil.

5.1-7 Wheel Bolt/Nut Inspection and Torquing Procedure

It is necessary to check the torque on all wheel nuts and wheel bolts at pre-delivery, after 8 hours of operation and at weekly intervals using the following procedure:

1. Confirm that each wheel fastener is torqued to 140 ft-lb. All fasteners must be torqued using the tightening sequence shown below.

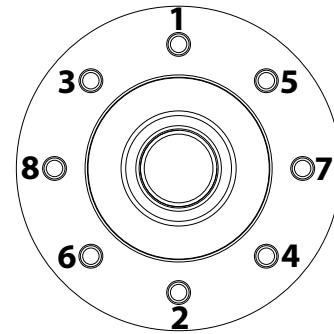

Diagram 5.4 Wheel Fastener Tightening Sequence

2. Again, confirm that each wheel fastener is torqued to the specified tolerance. Re-torque as necessary until all fasteners are properly torqued.

5.1-8 Wheel Reinstallation and Torquing Procedure

When a wheel/tire assembly has been removed or replaced, it will be necessary to follow the procedure below to ensure proper installation:

1. Inspect wheel fastener threads for damage of defects. Replace if defective.
2. Clean the mounting surfaces of the hub and wheel rim of debris, rust, excess paint, etc.
3. Mount wheel on the hub, centering mounting holes on the wheel studs or bolt holes. Use appropriate lifting device as required.
4. Install wheel nuts or wheel bolts and hand tighten to center the rim.
5. Torque nuts or bolts to approximately 50 ft-lb using the tightening sequence in [procedure 5.1-7](#).
6. Torque again to 100 ft-lb using the same sequence.
7. Torque again to 140 ft-lb using the same sequence.
8. Repeat the tightening sequence to confirm that none have changed from 140 ft-lb. If any are found below 140 ft-lb, repeat complete sequence until there is no change in torque values. If possible, drive the machine prior to checking torques.
9. Check torque values after 8 hours of operation and then at weekly intervals.

5.1-9 Front Axle Hub Procedure

For front axle hub components, refer to your aerial platform's parts manual.

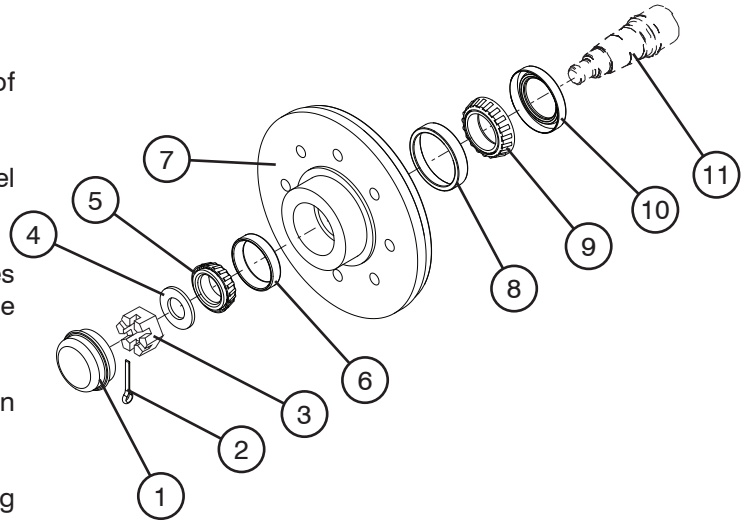

NOTE

Keep work area clean and visibly free from contamination at all times.

1. Ensure aerial platform is parked on a firm, level surface. Chock or block the wheels to keep the aerial platform from rolling forward or backward.
2. Fully lower the platform.
3. Using a suitable lifting device or outriggers (if equipped), lift the end of the aerial platform with the steer axle.



CAUTION

Use a suitably-rated support stand to support aerial platform while performing the following operations.

4. Turn emergency main power disconnect switch to "O" off position.
5. Remove wheel assembly.
6. Remove dust cap (item 1) to access internal components of hub assembly.
7. Pull cotter pin (item 2) out of spindle arm (item 11) and then remove castle nut (item 3), washer (item 4) and outer bearing cone (item 5). Dispose of dust cap, cotter pin, castle nut, washer, and outer bearing cone.

8. Flip hub over and then remove and discard inner bearing cone (item 8) and grease seal (item 10).
 9. Remove and discard both inner and outer bearing cups (items 6 & 8) from hub.
 10. Remove grease from spindle arm and hub and look for signs of visible damage. If damage is found on the hub or on the spindle arm, contact Service Department immediately using information found in page 2 for further instructions.
 11. Press new bearing cups (items 6 & 8) into hub.
 12. Pack replacement inner and outer bearings by either pressing wheel bearing grease into each roller by hand or using a bearing packer and grease gun. Ensure that grease is forced into all surfaces of the bearing.
- NOTE**
- Use only recommended wheel bearing grease - NLGI (National Lubricating Grease Institute) Grade #2 or equivalent.
- NOTE**
- The bearings must be packed before installing.
13. Install replacement inner bearing in the race and then seat the new grease seal. Flip hub over and install replacement outer bearing.
 14. Install hub on the spindle.
 15. Install replacement washer and replacement castle flanged nut. Hand tighten the castle flanged nut until it touches the washer. Turn hub by hand to ensure smooth running. No resistance should be felt at this time.
 16. Take a torque wrench and set it at 30 ft-lb, and while continuously rotating hub, tighten castle flanged nut. While hub is being turned and nut tightened, resistance will increase.
 17. Using an open-ended wrench, loosen castle flanged nut a 1/4 turn while turning the wheel hub. It should turn easily. The nut should not come completely loose.
 18. Using a torque wrench set to 15 ft-lb, tighten castle flanged nut. Turn wheel hub and check for smooth turning.
 19. Check for alignment of the castle flanged nut with one of the cross holes in spindle arm. If required, loosen nut to align with nearest hole. Use an open-ended wrench to be able to see the cross holes. The nut should not be turned more than 15 degrees. Secure with new cotter pin. Check again for smooth turning of wheel hub. The wheel hub should turn but with slight resistance.
 20. Grab the top and bottom of the hub and check for play. There should be no evidence of play.
 21. Install dust cap back on hub assembly.
 22. Install wheel assembly. Torque nuts or bolts to 140 ft-lb.
 23. Repeat steps 5 to 22 for the other hub assembly.
 24. Lower the aerial platform.

Outriggers

5.2-1 Auto-Leveling Outrigger PC Board Layout

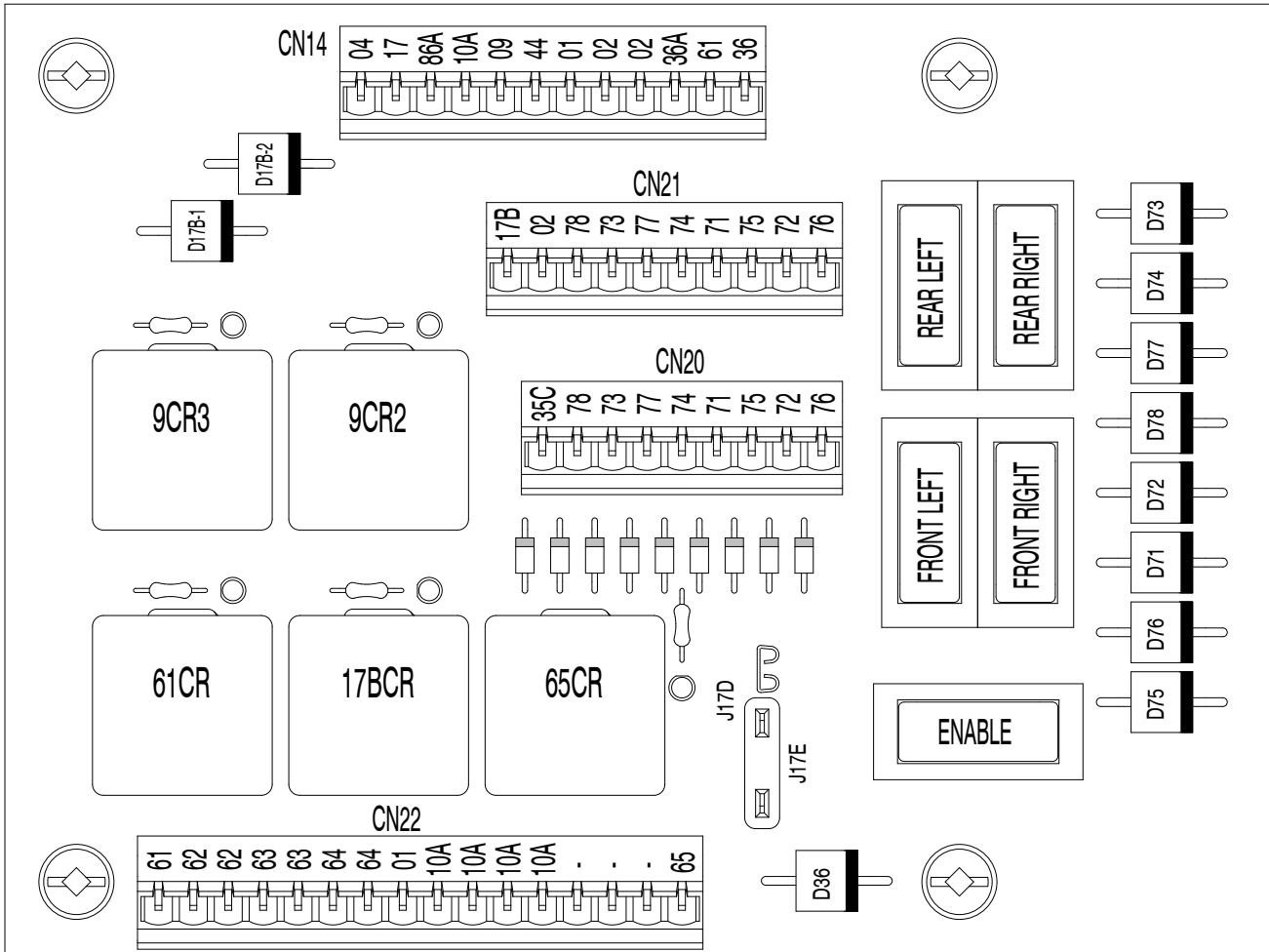

5.2-2 Outrigger Mechanical Limit Switch Wiring Diagram

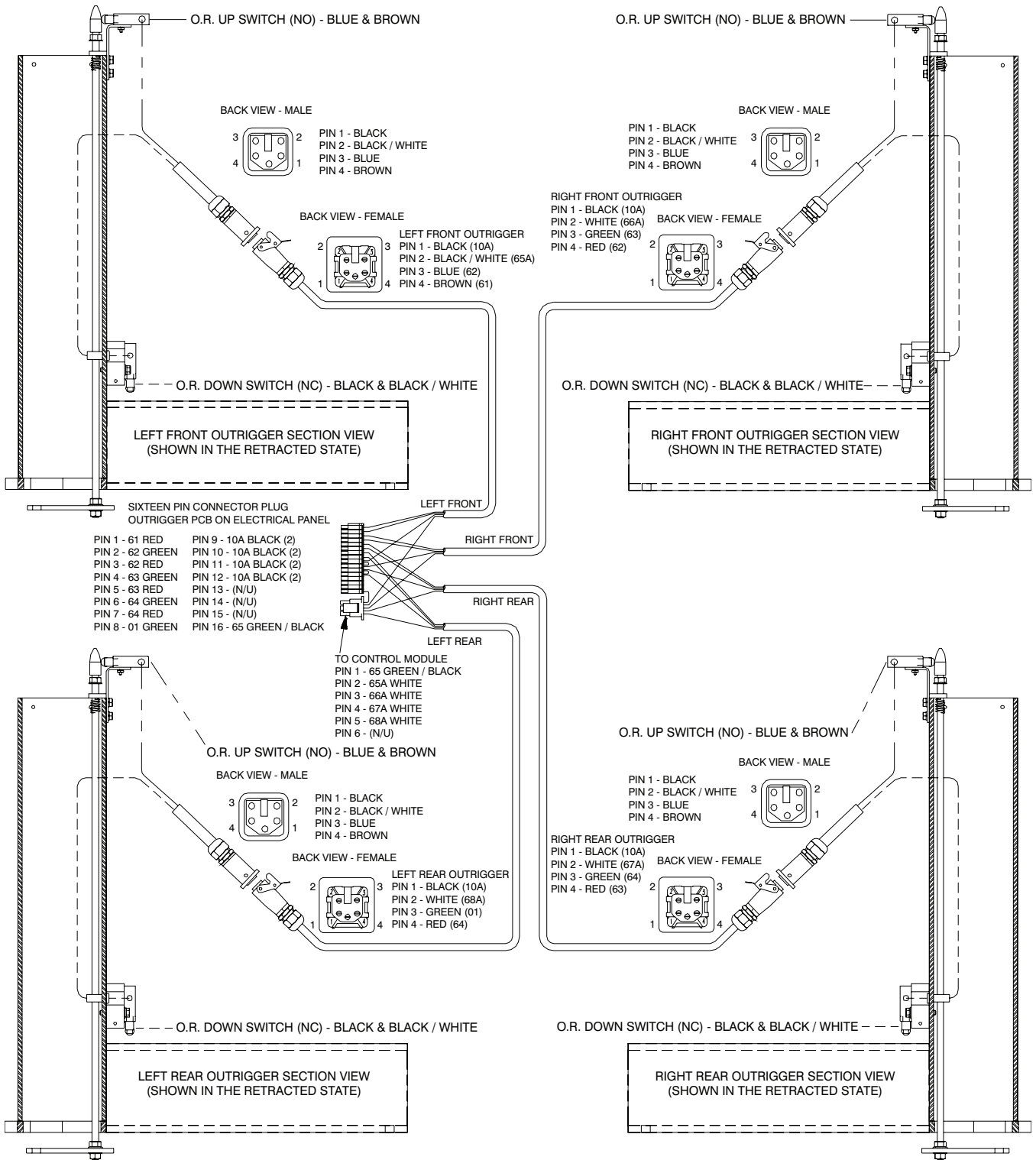

M11449AC

5.2-3 Auto-Leveling Outrigger Setting and Error Codes

Reading the Codes:

In order to read the fault codes, a sequence of pauses and flashes can be seen on the LED mounted on the outrigger control module. The codes are continuously displayed by the LED until the fault is cleared, the outrigger control module is reset and no longer detects the fault, or idle timeout becomes active.

The sequence is as follows:

1. Half second flashes followed by half second pauses indicate the first digit.
2. A 2.5 second pause.
3. Half second flashes followed by half second pauses indicate the second digit
4. A 5 second pause.

Repeat steps 1-4

Since the outrigger control module only reports one error, only one code can be read from the LED per instance. If the error is cleared and another error is present, it will then be presented.

LED Error Codes

EVERYTHING OK	ON
VEHICLE TILTED	1/1
OUTRIGGERS CANNOT BE MOVED!	1/2
OUTRIGGERS NOT HOME	2/2
NOT FULLY LEVEL	2/1
RELEASE OUTRIGGER DEMAND!	5/5
CHECK OUTRIGGER SUPPLY (P4-9)	5/2
CANNOT LEVEL : BAD TILT SENSOR	7/1
OUTRIGGERS MANUALLY CONTROLLED!	6/6
TESTING HWFS	7/8
B+ SUPPLY TOO LOW	5/1
STARTUP!	7/7
FAULT: BAD SLAVE MICRO	7/5
FAULT: BAD TILT SENSOR	7/1
FAULT: BAD HWFS	7/2
FAULT: P2-5 FAULTY	8/1
FAULT: P2-6 FAULTY	8/2
FAULT: P2-8 STUCK ON	8/3
FAULT: P2-8 ALWAYS ON	8/4
FAULT: P2-8 ALWAYS OFF	8/5
FAULT: HWFS STALLED!	7/6

60402AB

5.2-4 Auto-Leveling Outrigger Error Code Breakdown

RELEASE OUTRIGGER DEMAND!	5/5
Check inputs on P2 pins 5 & 6 - the "auto-level" or "auto-retract" input is active at power-on or when it is not allowed to carry out the function.	
OUTRIGGERS CANNOT BE MOVED!	1/2
Check input on P2 pin 10 – "auto-level" or "auto-retract" has been requested but the platform is elevated.	
NOT FULLY LEVEL	2/1
The outrigger legs are all down (touching the ground) but the platform is not fully level.	
OUTRIGGERS NOT HOME	2/2
The outrigger legs are not all down (touching the ground) and also are not all home (fully retracted).	
B+ SUPPLY TOO LOW	5/1
CHECK OUTRIGGER SUPPLY (P4-9)	5/2
Check that the battery voltage is not too low.	
VEHICLE TILTED	1/1
These is not a true fault – move the vehicle to level ground!	
TESTING HWFS	7/8
STARTUP!	7/7
These are not true faults unless they do not clear – the start-up tests should only occur for a short time.	
OUTRIGGERS MANUALLY CONTROLLED!	6/6
This is not a true fault – the outriggers are being manually operated (one or more outrigger legs on P4 pins 1-8 is high, when the outrigger control module is not active.	
CANNOT LEVEL (BAD TILT SENSOR)	7/1
FAULT: BAD TILT SENSOR	7/1
FAULT: BAD HWFS	7/2
FAULT: BAD SLAVE MICRO	7/5
FAULT: HWFS STALLED!	7/6
FAULT: P2-5 FAULTY	8/1
FAULT: P2-6 FAULTY	8/2
FAULT: P2-8 STUCK ON	8/3
FAULT: P2-8 ALWAYS ON	8/4
FAULT: P2-8 ALWAYS OFF	8/5
These are internal faults. If the fault persists after the power has been reset, the outrigger control module may need to be replaced.	

60412AB

5.2-5 Hand Held Calibration/Diagnostic Tool Key Functions



WARNING







Only trained and authorized personnel shall be permitted to service an aerial platform.

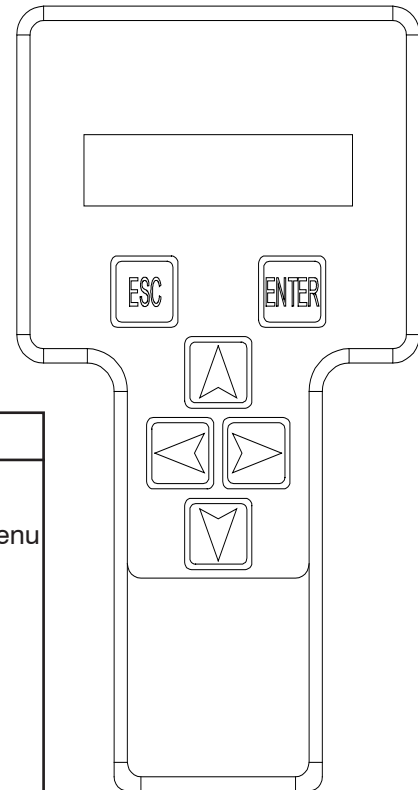

WARNING

Read all instructions closely before attempting each phase of this procedure.



SYMBOL	KEY FUNCTIONS
 	<p>ESC/ENTER BUTTONS To move back and forth between menu and sub-menu</p>
 	<p>LEFT/RIGHT BUTTONS Select menus and setting to be adjusted</p>
 	<p>UP/DOWN BUTTONS Adjust setting values</p>

Outrigger Settings

Model	SJIIIB 6826E	SJIIIB 6832E	7027	7127	7135	8243	8831	8831E	8841	8841E	8850	9241	9250
O.R. Settings	4	4	5	4	4	4	5	5	5	5	4	8	8

5.2-6 Outrigger Control Module Instructions

When EZcal hand-held device is connected to the OCM1 control module, a two line displays shows various menus and settings. At any time the top line of the display describes the currently selected menu and the bottom line shows the currently selected item in that menu.

Six buttons on **EZcal** allow easy navigation through the menus:

- ← and → change the selected item (the bottom line display)
- ENTER enters the selected new menu when available (top line display changes)
- ↑ and ↓ adjusts the selected item when available
- ESC exits the current menu back to the previous menu

TOP LEVEL MENU OPTIONS

HELP	Select this menu to see a description of current OCM1 status
DIAGNOSTICS	Select this menu to see switch input status & logged data
ACCESS LEVEL	Select this menu & enter correct code to enable adjustments and calibrations
ADJUSTMENTS	Select this menu to see and adjust OCM1 settings NOTE: this menu provides for adjustments which might be needed for different work activities
SETUPS	Select this menu to carry out initial set-up of the OCM1 NOTE: this menu provides for set-ups which are needed to configure the OCM1 for a particular vehicle

HELP MENU OPTIONS

(help message)	A message displays current OCM1 status, indicating if everything is OK or if there is an error code (see LED Error Codes - Table 5.3)
----------------	---

DIAGNOSTIC MENU OPTIONS

SYSTEM	Select this menu to see general OCM1 system information
SWITCHES	Select this menu to see switch input status
OUTPUTS	Select this menu to see OCM1 output status
LOG	Select this menu to see logged information

DIAGNOSTIC / SYSTEM MENU OPTIONS

OUTRIGGERS	Displays various status during the auto-level function
TILT	Displays vehicle tilt in "X" and "Y" orientations measured by integral sensor
TILTED	Displays whether vehicle is tilted (YES or NO)
BATTERY	Displays battery supply voltage (on P2-12)

DIAGNOSTIC / SWITCHES MENU OPTIONS

LR/P2-1	High when the left rear outrigger is in contact with the ground
RR/P2-2	High when the right rear outrigger is in contact with the ground
RF/P2-3	High when the right front outrigger is in contact with the ground
LF/P2-4	High when the left front outrigger is in contact with the ground
EXTEND/P2-5	High to activate the auto-level function
RETRACT/P2-6	High to activate the auto-retract function
ELEV/P2-10	High when the scissor stack is stowed ("elevated" input indicates that the vehicle is stowed).

DIAGNOSTIC / OUTPUTS MENU OPTIONS

LAMP/P2-7	Displays state of outrigger control box light
STABLE/P2-8	Displays state of stable (all legs touching the ground) output
TILT/P2-9	Displays state of tilt
LRe/P4-1	Displays state of left rear outrigger extend valve
RRe/P4-2	Displays state of right rear outrigger extend valve
RFe/P4-3	Displays state of right front outrigger extend valve
LFfe/P4-4	Displays state of left front outrigger extend valve
LRr/P4-5	Displays state of left rear outrigger retract valve
RRr/P4-6	Displays state of right rear outrigger retract valve
RFr/P4-7	Displays state of right front outrigger retract valve
LFr/P4-8	Displays state of left front outrigger retract valve
P4-9 MON	Displays the voltage to the outrigger valve (can only be seen when operating in auto-level or retract)

DIAGNOSTIC / LOG MENU OPTIONS

MAX.BATTERY	Displays maximum recorded battery supply voltage
OCM1 version	Displays part number and software version of GP106
EZcal version	Displays software version of EZcal

ACCESS LEVEL MENU OPTIONS

CODE xxxx	“ACCESS LEVEL” 3 (allows viewing only)
	“ACCESS LEVEL” 2 (allows setup on OCM1)

ADJUSTMENTS MENU OPTIONS (factory set - not adjustable)

Xtilt TRIP	Displays the tilt trip point in the “X” orientation
Ytilt TRIP	Displays the tilt trip point in the “Y” orientation
TILT ENTRY	Displays the tilt delay time
TILT EXIT	Displays the tilt delay time
Xlevel TRIP	Displays the tilt trip point in the “X” orientation during the auto-level function
Ylevel TRIP	Displays the tilt trip point in the “Y” orientation which applies during the auto-level function

MACHINE SETUP MENU OPTIONS (factory set - not adjustable)

DEFAULTS	Allows all adjustments & machine settings to be set to defaults WARNING: all GP106 settings will be changed; use with caution!
CALIBRATE LEVEL	Allows levelling of the integral tilt sensor of the GP106, when the vehicle is positioned on level ground (see Appendix Four)
TILT MODE	Allows configuration of the GP106 tilt output (P2-9): 1 – output turns on to light lamp when tilted 2 – output turns off to cutout functions when tilted 3 – output turns off to cutout functions when tilted AND elevated
TILT FILTER	Displays the filter applied to the tilt measurements during the auto-level function (used to minimize the effect of vehicle vibrations on the tilt measurement)
Xlevel TARGET	Displays the tilt in the “X” orientation at which the auto-level function will complete.
Ylevel TARGET	Displays the tilt in the “Y” orientation at which the auto-level function will complete.
tilt SLACK	Displays the amount of vehicle tilt exceeding the Xtilt TARGET and/or Ytilt TARGET in which the auto-level function will not attempt to level EXAMPLE: Xtilt TARGET=0.3°, Ytilt TARGET=0.7°, tilt SLACK=0.5° If machine is tilted to 1.0° in the X and Y orientations, the auto-level function will attempt to level the X orientation (0.3+0.5<1.0) but will not attempt to level the Y orientation (0.7+0.5>1.0) RANGE: 0.0° to 1.0°, default 0.3°

IMPORTANT

Each phase must be completed before the next phase can be carried out.
All phases must be completed before the aerial platform can be operated.
Always follow the instructions of the Calibration instrument.

1. Ensure aerial platform is parked on a firm and level surface.
2. Elevate the scissors high enough to lay a level across the base tubes. Ensure there is no debris on the base and the level sits flat. Do not elevate aerial platform higher than the high speed/tilt override limit switch.
3. Manually operate the outriggers and level the machine in 4 places: left side, right side, front and rear. All 4 outriggers must be firmly placed and all 4 tires are off the ground.
4. Double check that the aerial platform is level at all 4 points.
5. Connect the EZcal tool to the P1 connector on the **CONTROL MODULE**.
6. The display will show "**Help: Press Enter**".
By using Left/Right buttons, select the "**Access Level (3)**" from the menu and press the **ENTER** button.
7. The display will show "**Access Level: Code (0000)**".
By using the Up/Down buttons, enter the Access Level Code (1 → 1 → 2 → 2) followed by pressing the **ENTER** button.
8. The display will show "**Access Level 2**".
By using Left/Right buttons, select the "**Setups**" from the menu and press the **ENTER** button.
9. The display will show "**Setups: Change Defaults**".
Select the "**Change Defaults**" from the menu and press the **ENTER** button.
10. The display will show "**Defaults, 0 = Custom**".
By using Up/Down buttons, select the "Defaults: Code Setting for your Model (For Default Code Refer to Table 5-3)" from the menu and press the **ENTER** button and followed by **ESCAPE** button.
11. The display will show "**Setups Change Defaults**".
By using Left/Right buttons, select the "**Calibrate Level**" from the menu and press the **ENTER**.
12. The display will show "**Calibrate Level: Yes: Enter, No: ESC**".
Select the "**Yes**" from the menu by press the **ENTER** button.
13. The display will show "**Calibrate Level: Tilt 0.0' , 0.0'**".
Select the "**ESCAPE**" from the menu once.
14. The display will show "**Setups Calibrate Level**".
Select the "**ESCAPE**" from the menu once again.
15. The Calibration procedure is complete, unplug and remove the EZ-Cal.
16. Close the hydraulic/electric cabinet.

5.2-7 Auto-Leveling Outrigger Control Module Pin Reference Chart

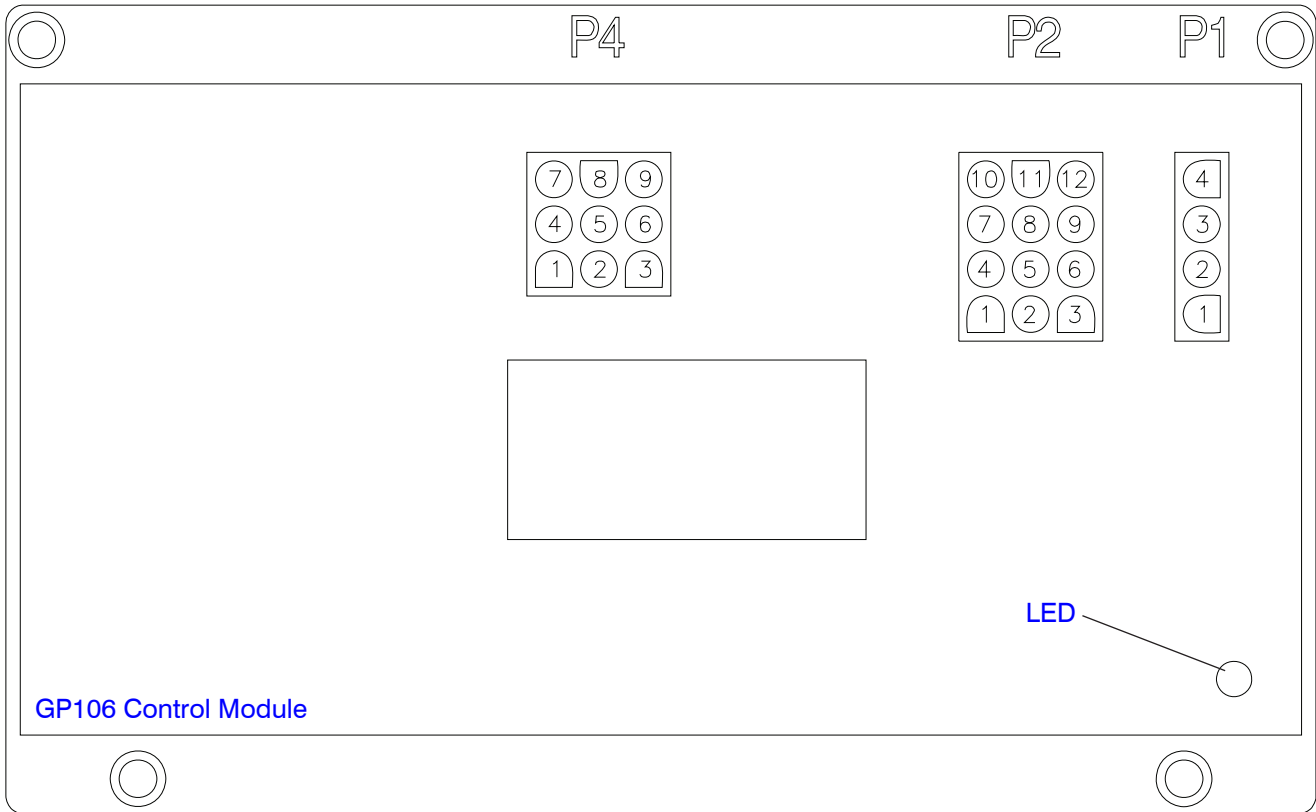

PLUG	PIN #	WIRE # AND COLOUR	WIRE FUNCTION
P1	The Calibration Connection		
P2	1	68A White	Input indicating that the LEFT REAR outrigger is in contact with the ground
P2	2	67A Red/White	Input indicating that the RIGHT REAR outrigger is in contact with the ground
P2	3	66A Blue/White	Input indicating that the RIGHT FRONT outrigger is in contact with the ground
P2	4	65A Green/White	Input indicating that the LEFT FRONT outrigger is in contact with the ground
P2	5	70 Green/Black	Input for AUTO-LEVEL function to extend the outriggers to level the machine
P2	6	79 Green	Input for AUTO-RETRACT function to retract the outriggers until the switch is released
P2	7	70A Red/White	Outrigger Light on Outrigger Control Box
P2	8	65 Green/Black	STABLE output to indicate that all outriggers are in contact with the ground
P2	9	28 Green	TILT output to indicate that the machine is level (ANSI/CSA only)
P2	10	35 Green	Tilt override / High Drive Cutout
P2	11	02 White	Negative Input
P2	12	10A Black	Main Power Input
P4	1	78 Black/White	Output used to extend the LEFT REAR outrigger
P4	2	77 Blue/Black	Output used to extend the RIGHT REAR outrigger
P4	3	76 Red/Black	Output used to extend the RIGHT FRONT outrigger
P4	4	75 Orange/Black	Output used to extend the LEFT FRONT outrigger
P4	5	74 Black	Output used to retract the LEFT REAR outrigger
P4	6	73 Blue	Output used to retract the RIGHT REAR outrigger
P4	7	72 Red	Output used to retract the RIGHT FRONT outrigger
P4	8	71 Orange	Output used to retract the LEFT FRONT outrigger
P4	9	35C White/Black	Power input for outriggers

60401AB

5.2-8 Outrigger Upper Limit Switch (LS61, LS62, LS63, LS64) Replacement and Adjustment

Machine Preparation

1. Ensure the aerial platform is parked on a firm level surface.
2. Fully retract the outriggers.
3. Turn the emergency main power disconnect switch to the OFF position.
4. Chock or block the wheels to keep the aerial platform from rolling forward or backward.

Limit Switch Removal

1. Remove the bolts and washers (x4) securing the upper limit switch/hose cover. Set aside the hardware and cover for reinstallation later.
2. Remove the washers, bolts, and nuts (x2) securing the limit switch to the bracket. Set aside for reinstallation later.

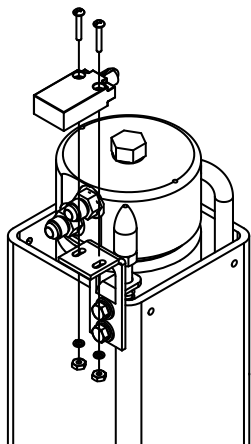

3. Remove the limit switch cable from the split loom tubing, cutting tie wraps and tape as needed to free it.
4. Disconnect the connector, and remove the applicable limit switch wires and ferrules, retaining the connector for reuse later. Discard the old limit switch and cable.

Limit Switch Replacement

1. Mount the new limit switch (**115658**) loosely on the bracket, using the hardware removed previously.
3. Starting from the top, place the new limit switch cable in the split loom.
4. Adjust the cable in the split loom as needed, and close the split loom by wrapping electrical tape around it at regular intervals. Tie wrap the split loom to the hoses.
5. Cut off any unneeded length from the cable, and strip the end to exposed the wires beneath.
6. Strip the ends from each wire and crimp a ferrule to each wire end.
7. Insert the wires into the connector end removed previously (refer to [3.13 Auto-Leveling Outrigger Wiring Diagram](#)). Reconnect the connector.

Limit Switch Adjustment

1. With the outriggers retracted, slide the limit switch on the bracket until the plunger is depressed against the actuator rod cap. Apply a small amount of Loctite to the bolts, and tighten the bolts and nuts.

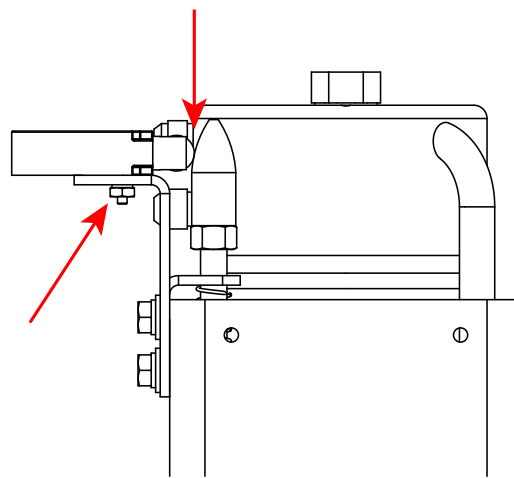

Limit Switch Testing

1. Turn emergency main power disconnect switch to the ON position, and start the engine.
2. With the outriggers fully retracted, the unit should be driveable. With the outriggers extended more than halfway, the unit should not be driveable.

5.2-9 Outrigger Lower Limit Switch (LS65, LS66, LS67, LS68) Replacement and Adjustment

Machine Preparation

1. Ensure the aerial platform is parked on a firm level surface.
2. Fully retract the outriggers.
3. Turn the emergency main power disconnect switch to the OFF position.
4. Chock or block the wheels to keep the aerial platform from rolling forward or backward.

Limit Switch Removal

1. Remove the bolts and washers (x4) securing the upper limit switch/hose cover. Set aside the hardware and cover for reinstallation later.
2. Remove the screws (x2) securing the lower limit switch cover. Set aside the hardware and cover for reinstallation later.
3. Remove the washers and screws (x2) securing the limit switch to the mount. Set aside for reinstallation later.

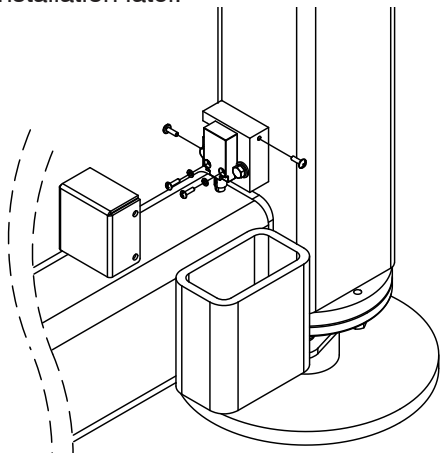

4. Cut the tie wraps and tape around the split loom as needed to expose the limit switch cable.
5. Disconnect the applicable wires from the connector, and cut the ferrules off of the wires on the end of the cable. Retain the connector for reuse later.

6. Remove the cable from the split loom. Gently pull the cable down through the outrigger weldment, and through the rubber grommet. Retain the rubber grommet. Discard the old limit switch and cable.

Limit Switch Replacement

1. Install a new limit switch (**115658**) to the mounting block using the hardware removed earlier.
2. Feed the new cable through the rubber grommet, and place the grommet in the hole in the outrigger weldment.
3. Feed the cable up through the outrigger weldment, until it comes out the top.
4. Working from top to bottom, adjust the cable in the split loom and close the split loom by wrapping electrical tape around it at regular intervals. Tie wrap the split loom to the hoses.
5. Cut off any unneeded length from the cable, and strip the end to expose the wires beneath.
6. Strip the ends from each wire and crimp a ferrule to each wire end.
7. Insert the wires into the connector end removed previously (refer to [3.13 Auto-Leveling Outrigger Wiring Diagram](#)). Reconnect the connector.

Limit Switch Adjustment

8. Loosen the bolts securing the mounting block to the outrigger, and slide the block until the limit switch plunger is depressed halfway against the base weldment. Apply a small amount of Loctite to the bolts, and tighten them.

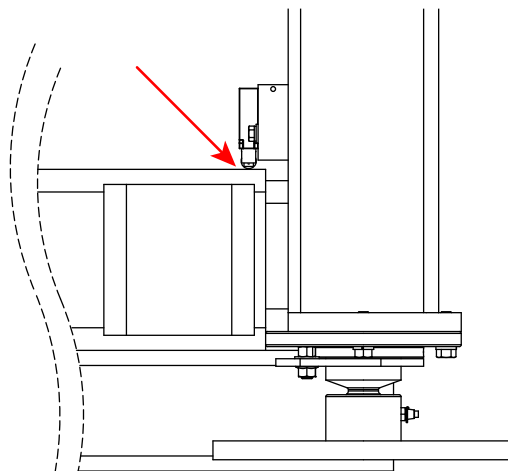

Limit Switch Testing

1. Turn emergency main power disconnect switch to the ON position, and start the engine.
2. With the outriggers fully retracted, the unit should be driveable. With the outriggers extended more than halfway, the unit should not be driveable.

Scissors

5.3-1 End of Stroke Limit Switch (LS4) Replacement and Adjustment

Machine Preparation

1. Ensure the aerial platform is parked on a firm level surface.
2. Chock or block the wheels to keep the aerial platform from rolling forward or backward.

Limit Switch Removal

1. Raise the platform until the scissor slider tracks are accessible. Deploy the maintenance stand.
2. Locate the end of stroke limit switch assembly in the rear left scissor slider track. Loosen the 1/4" flat screws holding the assembly in place, and slide the assembly out of the track.

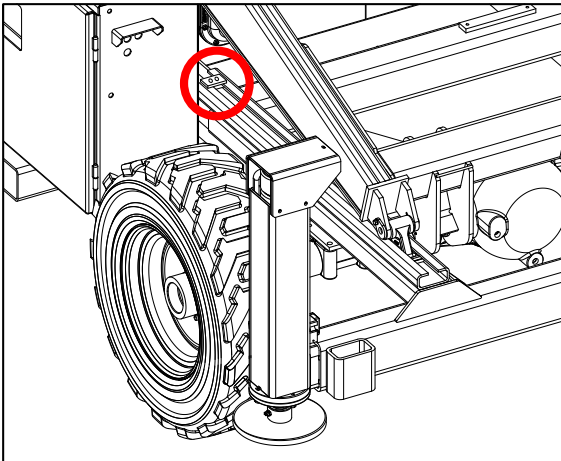

3. Remove the 1/4" flat screws from the limit switch locking plate, then remove the #8 screws and washers mounting the limit switch to the limit switch mounting plate. Retain the hardware and plates for reassembly later.
4. Cut the tie wraps securing the limit switch cable until the cable is free.
5. Disconnect the limit switch cable wires from the electrical panel in two places. Discard the old limit switch.

Limit Switch Replacement

1. Mount the new limit switch (**115658**) to the underside of the mounting plate using the #8 lock washers and screws removed in step 3. The locking plate and 1/4" flat screws will be reinstalled later.

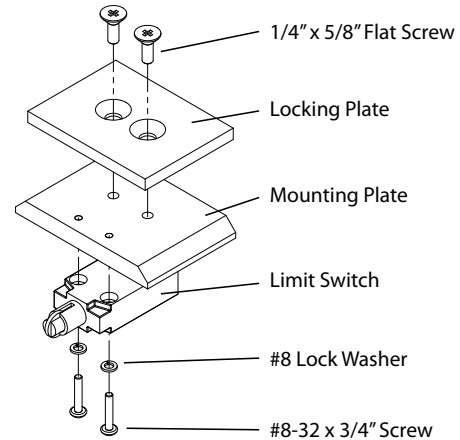

Limit Switch Electrical Connection

1. Route the new limit switch cable along the same path as the old one into the cabinet, using tie wraps as needed to secure it at regular intervals.
2. Strip the cable jacket back to separate the wires. Cut the black wire to length if needed, strip the end, and crimp a ferrule onto it. Insert it into the 45 degree header on the PC board (refer to [3.16 Electrical Panel Diagram \(KC\)](#)).
3. Cut the black and white wire to length if needed. Strip the end and fasten it to the upper screw on socket 14CR on the electrical panel (refer to [3.16 Electrical Panel Diagram \(KC\)](#)).
4. Stow the maintenance stand and fully lower the platform.

Limit Switch Adjustment

2. Attach the end of a measuring tape to the side of the platform with a tie wrap, in such a way that the measuring tape will hang down freely to the ground.

Note: The end of the measuring tape should be level with the standing surface of the platform.
3. Raise the platform until the distance from the standing surface of the platform to the ground measures 50 ft / 15.24 m.
4. Using a piece of masking tape, mark the location of the end of the bottom slider assembly in the rear left scissor slider track.

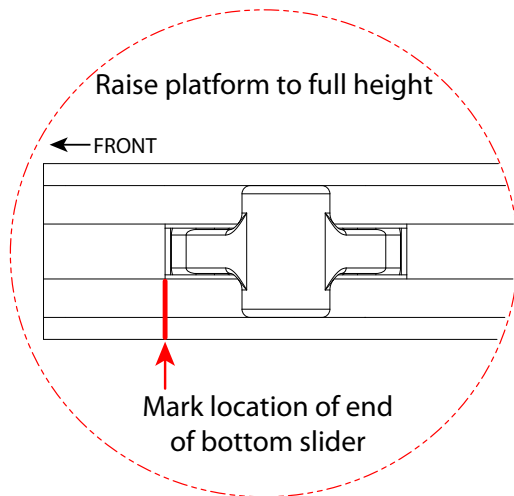

5. Lower the platform slightly until the end of the bottom slider assembly moves 1/2 in / 1.25 cm from the mark.

6. Slide the new limit switch assembly into the slider track. Align the locking plate on the slider track, and loosely secure it to the mounting plate with the 1/4" flat screws (apply Loctite to the screws before installing). Slide the assembly in until the limit switch plunger touches the slider. Tighten the 1/4" flat screws.

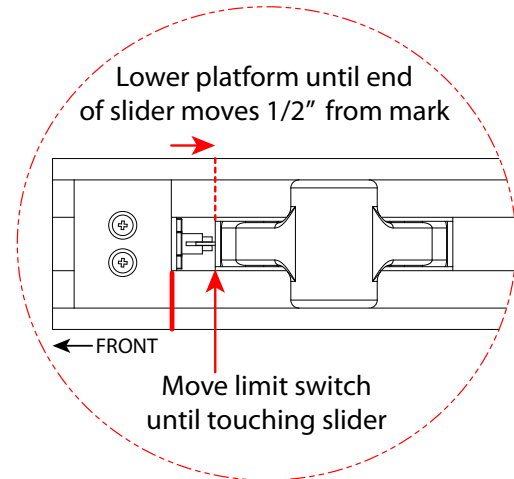

7. Fully lower the platform.

Limit Switch Testing & Cleanup

1. Raise the platform. The platform should stop at full height when the scissor slider assembly depresses the limit switch plunger.
2. Lower the platform and remove the measuring tape from the platform. Remove the masking tape from the slider track.
3. Remove the chocks or blocks from the wheels.

5.3-2 High Speed Cutout (LS5) and Lift Cutout (LS1) Limit Switch Replacement and Adjustment

Machine Preparation

1. Ensure the aerial platform is parked on a firm level surface.
2. Chock or block the wheels to keep the aerial platform from rolling forward or backward.

Limit Switch Removal

1. Raise the platform to give access to the limit switch cable(s), and deploy the maintenance stand.
3. Turn the emergency main power disconnect switch to the OFF position.
2. Remove the bolts, washers, and nuts (x2) securing the limit switch cover. Set aside the hardware and cover for reinstallation later.
3. Remove the bolts and washers (x2) securing the limit switch to the bracket. Set aside for reinstallation later.

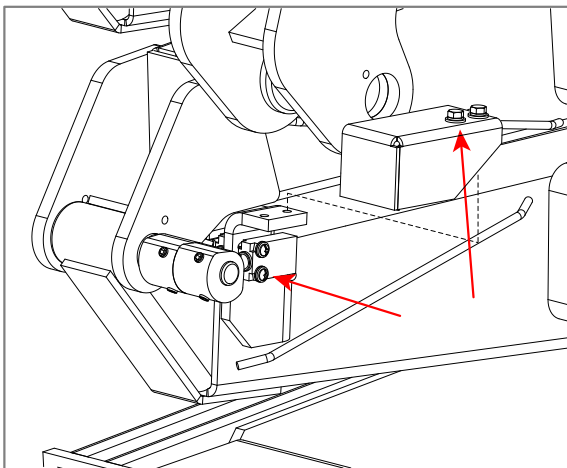

4. Remove the limit switch(es) and free the limit switch cable(s) by cutting the tie wraps.
5. Follow the cable(s) into the electrical panel, and disconnect the limit switch wires from the electrical panel. Discard the limit switch(es).

Limit Switch Replacement

1. Mount the new limit switch(es) (119296 for High Speed Cutout, and 119375 for Lift Cutout) on the bracket, using the hardware removed previously (apply a small amount of Loctite to the bolts).

Note: The High Speed Cutout Limit Switch is the one closest to the scissor arm.

Limit Switch Electrical Connections

1. Route the new limit switch cable(s) along the same path as the old one(s) into the electrical panel cabinet. Use tie wraps as needed to secure them at regular intervals.
2. **For the High Speed Cutout Limit Switch** - Strip the cable jacket back to separate the wires. Cut the wires to length if needed, strip the ends, and insert them into the terminal block (refer to 3.16 Electrical Panel Diagram (KC)).
2. **For the Lift Cutout Limit Switch** - Strip the cable jacket back to separate the wires. Cut the wires to length if needed, strip the ends, and crimp ferrules onto the wire ends. Insert them into the 45 degree header on the PC board (refer to 3.16 Electrical Panel Diagram (KC)).
4. Stow the maintenance stand and fully lower the platform.

Limit Switch Cam Setup

1. Turn emergency main power disconnect switch to the ON position, and start the engine.
2. Attach the end of a measuring tape to the side of the platform with a tie wrap, in such a way that the measuring tape will hang down freely to the ground. **Note:** The end of the measuring tape should be level with the standing surface of the platform.
3. **For the High Speed Cutout Limit Switch** - Raise the platform until the distance from the standing surface of the platform to the ground measures 10 ft / 3.05 m.
4. Loosen the set screws (x2) on the high speed cutout cam, and rotate the cam until it depresses the limit switch plunger. Apply a small amount of Loctite to both set screws, and tighten them.

3. **For the Lift Cutout Limit Switch** - Raise the platform until the distance from the standing surface of the platform to the ground measures 26 ft / 7.92 m.
4. Loosen the set screws (x2) on the lift cutout cam, and rotate the cam until it depresses the limit switch plunger. Apply a small amount of Loctite to both set screws, and tighten them.

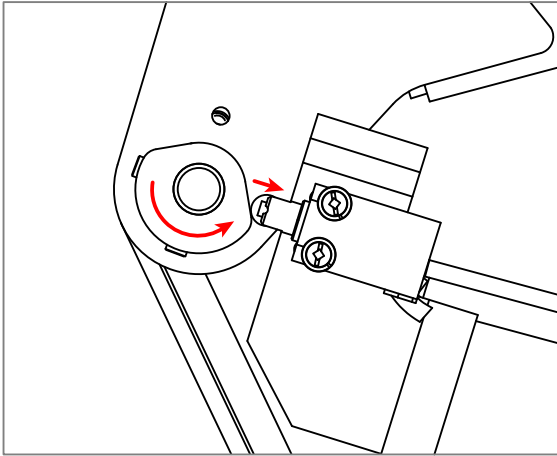

Limit Switch Testing

1. **For the High Speed Cutout Limit Switch** - Raise the platform less than 10 ft / 3.05 m, and drive the unit at full speed. Then raise the platform over 10' ft / 3.05 m. The unit should automatically switch from high speed to low speed.
2. **For the Lift Cutout Limit Switch** - Raise the platform over 26 ft / 7.92 m and try to drive the unit. The unit should not drive. Then lower the platform to below 26 ft / 7.92 m. The unit should drive.

Platform

5.4-1 Gate Spring Hinge Adjustment

1. The tension of the spring hinges should be such that when the gate is opened halfway and released, it will close fully and latch.
2. To adjust the tension of the spring hinges, first remove the safety locking screw located at the top or bottom of each hinge. Retain the screws for reinstallation later.
3. To increase the tension, insert a 5/32" hex wrench in the screw socket, and turn the wrench clockwise. To release the tension, depress the hex wrench in the socket, let it rotate counterclockwise, then release the hex wrench.

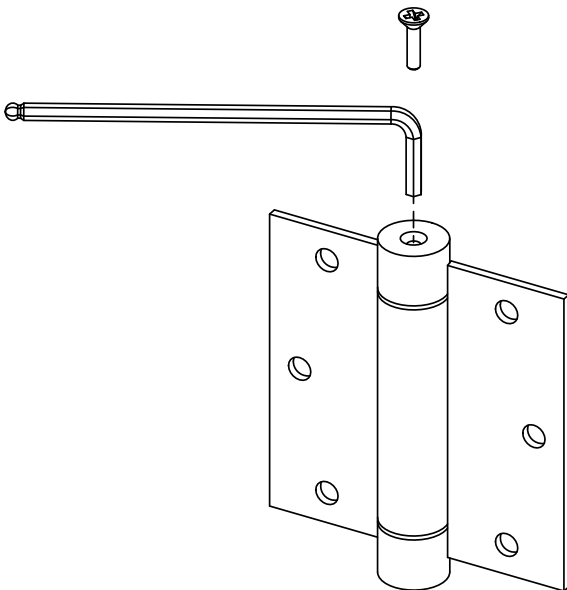

4. Adjust the tension on both hinges until the gate releases and latches from a half open position.
5. Reinstall the safety locking screws into the hinges when tension adjustment is complete.



Reliable lift solutions by people who care.

www.skyjack.com